

KHL REGULATIONS

SEASONS 2017/2018, 2018/2019, 2019/2020, 2020/2021

APPROVED BY

CHL LLC Board of Directors
(minutes No. 75 dated July 14, 2017)

As amended and supplemented and approved
by the CHL LLC Board of Directors
(minutes No. 76 dated August 21, 2017,
minutes No. 85 dated July 4, 2018;
minutes No. 87 dated August 30, 2018;
minutes No. 96 dated July 4, 2019;
minutes No. 98 dated August 27, 2019)

KHL TECHNICAL REGULATIONS

Whereas the official language of the Kontinental Hockey League Championship is Russian,
in case of inconsistency between the Russian and English versions of the KHL Regulations
the Russian text shall prevail

Moscow, 2019

KHL TECHNICAL REGULATIONS

TABLE OF CONTENTS

| | |
|--|-----------|
| CHAPTER 1. REQUIREMENTS FOR SPORTS FACILITIES | 3 |
| ARTICLE 1. GENERAL REQUIREMENTS FOR SPORTS FACILITIES..... | 3 |
| ARTICLE 2. THE NUMBER OF INDIVIDUAL SEATS FOR SPECTATORS AT SPORTS FACILITIES | 4 |
| ARTICLE 3. REQUIREMENTS FOR THE INFRASTRUCTURE OF SPORTS FACILITIES..... | 4 |
| CHAPTER 2. SAFETY ARRANGEMENTS | 17 |
| ARTICLE 4. GENERAL SAFETY PROVISIONS | 17 |
| ARTICLE 5. RESPONSIBILITY FOR SAFETY AND SECURITY ARRANGEMENTS..... | 17 |
| ARTICLE 6. ORGANIZATION OF MEASURES TO ENSURE SECURITY DURING THE CHAMPIONSHIP GAMES..... | 18 |
| ARTICLE 7. HIGH-RISK GAMES..... | 20 |
| CHAPTER 3. SPECTATORS (SUPPORTERS) | 20 |
| ARTICLE 8. RESPONSIBILITY | 20 |
| ARTICLE 9. REQUIREMENTS TO CLUBS RELATING TO INTERACTION WITH SPECTATORS (SUPPORTERS)..... | 21 |
| ARTICLE 10. AWAY SECTOR (SECTOR FOR ACTIVE SUPPORT)..... | 21 |
| ARTICLE 11. MEMORABILIA, MEANS OF SUPPORTING..... | 22 |
| ARTICLE 12. TICKET PROGRAM..... | 24 |
| CHAPTER 4. FINAL PROVISIONS | 25 |
| <i>APPENDIX 1</i> | 26 |
| CERTIFICATE OF COMPLIANCE OF THE SPORTS FACILITY AND HOCKEY CLUB WITH THE TECHNICAL REGULATIONS OF THE KONTINENTAL HOCKEY LEAGUE CHAMPIONSHIP – RUSSIAN ICE HOCKEY CHAMPIONSHIP | 26 |
| <i>APPENDIX 2</i> | 41 |
| CERTIFICATE OF READINESS | 41 |
| <i>APPENDIX 3</i> | 43 |
| CERTIFICATE OF INSPECTION | 43 |
| <i>APPENDIX 4</i> | 45 |
| KHL CERTIFICATE PROVISION | 45 |
| <i>APPENDIX 5</i> | 49 |
| VIDEO-GOAL SYSTEM CAMERA LOCATIONS AND IMAGES | 49 |
| <i>APPENDIX 6</i> | 51 |
| CODE OF CONDUCT FOR SPECTATORS IN SPORTS FACILITIES (FOR KHL AND JHL HOCKEY GAMES) | 51 |
| <i>APPENDIX 7</i> | 55 |
| DESIGNED SPORTS FACILITIES | 55 |
| <i>APPENDIX 8</i> | 57 |
| REQUIREMENTS FOR PREPARING AND USING THE ICE SURFACE | 57 |
| <i>APPENDIX 9</i> | 59 |
| BOARD SYSTEM REQUIREMENTS | 59 |

CHAPTER 1. REQUIREMENTS FOR SPORTS FACILITIES

Article 1. General Requirements for Sports Facilities

1. Club teams whose “home” Games are held at Sports Facilities compliant with these Regulations are admitted for participation in the Championship.
2. Sports Facilities selected for Championship Games must be completed and accepted by the government commission before the Championship start date, obtain permissions for operation, and comply with the requirements of the Rule Book of the Hockey Game.
3. Sports Facilities selected for the Championship Games must comply with the “Requirements for certain infrastructure objects of sports facilities for official sports competitions and technical equipment of stadiums to ensure public order and safety” approved by Order No. 1092 of the Ministry of Internal Affairs of Russia dd. November 17, 2015 in accordance with the Decree No. 353 of the Government of the Russian Federation “On the approval of Rules for ensuring safety during official sports competition” dd. April 18, 2014 (for Russian clubs only).
4. Sports Facilities selected for the Championship Games must obtain the following documents:
 - 1) certificate registered by a government body on physical training and sports of the respective subject of the Russian Federation pursuant to a standard form approved by Order No. 117 of the State Committee of the Russian Federation for Physical Education and Tourism “On certification and non-recurring registration of sports facilities” dd. April 8, 1996 (for Russian Clubs only);
 - 2) safety certificate of a Sports Facility in accordance with the Decree of the Russian Government No. 202 “On approval of requirements for anti-terrorism security of sports facility and form of the security certificate of sports facilities” dd. March 6, 2015, Instruction on ensuring public security at a sports facility during official sports competitions, Action plan on measures to ensure public order and security at a sports facility during official sports competitions approved by Order No. 948 of the Ministry of Sport of the Russian Federation dd. November 26, 2014 (for Russian Clubs only).
5. Sports Facilities must be included in the All-Russian register of sports facilities (for Russian Clubs only).
6. Sports Facilities selected for “home” Championship Games by foreign KHL Clubs must obtain the Sports Facility passport or a similar document registered in accordance with their national laws.
7. Ownership rights with respect to Sports Facilities selected for the Championship Games must be registered in the Unified State Register of Property Rights and Transactions before the Championship start date. Foreign Sports Facilities must obtain registered documents confirming the respective ownership rights in accordance with their national laws.
8. On an annual basis, Employees supporting the activities of the respective services of the Sports Facility must read and acknowledge in writing the following documents before August 1 (for Russian Clubs only):
 - a) Order No. 44 of the Committee of the Russian Federation for Physical Education and Sports “On ensuring safety and prevention of injuries related to physical training and sports” dd. April 1, 1993;
 - b) Order of the Committee for Physical Education and Sports of the Council of Ministers of the USSR No. 786 “On introduction of the “Regulation on measures to ensure public order and security, as well as evacuation and alerting of participants and spectators during mass sports events”” dd. October 17, 1983; Decree of the Russian Government No. 353 “Rules for ensuring security during official sports events” dd. April 18, 2014;
 - c) Federal Law No. 192-FZ “On amendments to certain legislative acts of the Russian Federation in connection with ensuring public order and security during official sports competitions” dd. July 23, 2013.
9. Compliance with the requirements of the above-mentioned legislative acts must be ensured by the Sports Facility administration during any Games or other Championship events.
10. On an annual basis, each Sports Facility selected for Championship Games must obtain a

KHL TECHNICAL REGULATIONS

certificate of readiness for operation from a specialized commission before August 1. Among other matters, the above-mentioned certificate must contain the commission's conclusion on reliability and stability of building structures and technical systems, compliance of spectator evacuation routes with specified standards, sports and engineering environment of future Games.

(last updated on July 4, 2019. Minutes of meeting of CHL LLC Board of Directors No. 96 dated July 4, 2019)

11. Before the Championship mandatory third party liability of the hockey Games organizer must be covered (tenants, free-of-charge users of the Sports Facilities or owners of the Sports Facilities where Championship Games are to be held).
12. Each year before the Championship every Club must complete and forward to the League the Certificate of Compliance of the Sports Facility with the requirements of these Regulations signed by the Sports Facility director, Club director (Appendix 1 to the KHL Technical Regulations).
(last updated on July 4, 2019. Minutes of meeting of CHL LLC Board of Directors No. 96 dated July 4, 2019)
13. No later than 4 hours before starting a Game, the Certificate of the Sports Facility readiness for the Championship Game must be completed (Appendix 2 to the KHL Technical Regulations). No later than 3 hours before starting a Game, the competition venue shall be inspected from the operational and technical point of view, and no later than 1 hour before starting a Game, the respective Inspection Report shall be completed and presented to the Chief Referee (Appendix 3 to the KHL Technical Regulations). The above-mentioned documents shall be stored for three (3) years after finishing the Championship.
14. When planning any constructive and technical modifications (reconstruction) of the Sports Facility at which the Club holds "home" Championship Games, the Club shall agree future modifications (reconstruction) with KHL in order to comply with the requirements of these Regulations and make it possible for KHL to reflect the respective modifications in the Database of Sports Facilities.
15. The designed (constructed) Sports Facility for Championship Games must fully comply with the requirements of these Regulations (together with Appendix 7 "Designed Sports Facilities" to the KHL Technical Regulations).
16. With respect to technical characteristics of the Sports Facility that affects the safety of sportsmen and spectators during a Game (safety netting, glass, board systems, ice preparation systems, air conditioning systems, lighting systems, etc.); KHL introduces requirements that are mandatory for Clubs participating in the Championship.

Article 2. The number of individual seats for spectators at Sports Facilities

1. The number of individual seats for spectators at a Sports Facility must be no less than five thousand and five hundred (5,500).
2. Clubs that are based in cities with a population of less than one hundred thousand (100,000) people are allowed to hold the Championship Games at Sports Facilities with a seating capacity of less than five thousand and five hundred (5,500) but no less than two thousand and five hundred (2,500) seats, and the Sports Facilities must comply with the remaining requirements to Sports Facilities set out in the KHL Technical Regulations.

Article 3. Requirements for the infrastructure of Sports Facilities

1. Each Sports Facility selected for the Championship Games must have the following infrastructure:
 - 1.1. Hockey rink equipped in accordance with the Rule Book of the Hockey Game with:
 - a) goal net with elastic locks with a total length of at least 20 cm and thin part length at least 12 cm fixed in special inserts in a concrete plate, and video cameras of the Video Goal System inside the goal net in white protective cases. Goal nets that are used during pregame warm-up must comply with the requirements for goal nets that are used during the Game, except for Video Goal cameras. At the Sports Facility, game goals must be selected, as well as the goal net for pregame warm-up that are used during KHL Championship Games only.

KHL TECHNICAL REGULATIONS

The goals must be free from damages, paint fractures and contamination on the frame, buffer stuffing and net damages and contamination. The goals must have a standard color based on the RAL 3020 table. The game goals must have white fixtures made of a polymer material to fix plastic water bottles on the upper rear part of central goal posts;

(last updated on August 21, 2017. Minutes of meeting of CHL LLC Board of Directors No. 76 dated August 21, 2017)

- b) strobes installed above the game goals on the ceiling of the Sports Facility or another lighting equipment regardless of its location that is installed to turn on and create lighting effect (impulse) when a goal is scored;
- c) shields made of safety glass/acryl behind the goal net and along the boards at least 160 cm high; taking account of the scheduled replacement of board systems, requirements of paragraph 4.1, clause 4, of Appendix 9 to the KHL Technical Regulations shall be applied;
- d) the safety glass/acryl shields must be coplanar along the entire board perimeter. Gaps between safety glass/acryl shields must be closed with inserts to the safety glass/acryl shield height along the entire perimeter of the hockey rink;
- e) replacement sections of the safety glass/acryl shield for prompt replacement in case of their breakage;
- f) safety shield with a canopy (if the height of the safety shield is not sufficient) made of safety glass/acryl behind the benches and at edges of Players' Benches and Penalty Boxes that separate Hockey Players on Players' Benches and in Penalty Boxes from spectators. The safety shield height and canopy construction must prevent contacts between Hockey Players, team representatives, Game officials and spectators, as well as appearance of items thrown from the grandstands to Players' Benches, Penalty Boxes and Game officials. Gaps must be closed with inserts to the safety glass/acryl shield height. No gaps between sections are allowed;
- g) safety glass/acryl shield (divider) between Players' Benches of both teams;
- h) high strength netting over the safety glass to separate spectators behind the goals from the hockey rink, at least 10 m high, tilted 80 grades with respect to the horizontal plane towards the grandstands;

(last updated on July 4, 2019. Minutes of meeting of CHL LLC Board of Directors No. 96 dated July 4, 2019)

- i) safety shield along ice hockey rink boards to protect advertisement boards;
- j) self-stick advertisement with silicone surface. It is also allowed to install media panels in the board systems on the rink side; each panel width must be the same as a single board section width. Layout and size of media panels shall be agreed with KHL;
- k) special cover to prevent injuries along the board perimeter on the hockey rink side and installed at the joint of the upper board edge with the safety glass/acryl shield for board systems with a width of more than 40 mm; safety stuffing for the entire glass height or a special rounding in gaps of the safety glass/acryl shield;
- l) high-quality ice surface prepared in compliance with Appendix 8 to the KHL Technical Regulations with clearly visible official marking in accordance with the Rule Book of the Hockey Game. Before the season start and prior to flooding the rink to form the ice surface KHL Hockey Clubs must agree with the Department of Competitions and CHL LLC a planogram of advertisement placement and/or other information on the ice surface to ensure its compliance with the Rule Book of the Hockey Game. KHL Hockey Clubs must ensure renewal of the hockey rink marking during Championship breaks and after the end of the Championship Stage One. The marking colors must comply with the RAL table (red — 3020, blue — 5005, light blue — 5012);
- m) A container for cooling pucks before the start of and during the Game;
- n) Deleted.

(last updated on July 4, 2018. Minutes of meeting of CHL LLC Board of Directors No. 85 dated July 4, 2018)

- o) A STM System installed by the KHL. The STM System equipment shall be synchronized

KHL TECHNICAL REGULATIONS

with a Sports Facility countdown chronometer of the play time. The Club shall prevent, during the pre-game warm-ups and Games, placement of any items disturbing the operation of the STM System equipment, in particular, prevent placement of items between the locator and the ice rink.

(last updated on August 27, 2019. Minutes of meeting of CHL LLC Board of Directors No. 98 dated August 27, 2019)

- 1.2. Requirements at the Sports Facilities where KHL Clubs hold “home” Games must be met with respect to board systems and stage-by-stage replacement of board systems (Appendix 9 to the KHL Technical Regulations).
(last updated on July 4, 2018. Minutes of meeting of CHL LLC Board of Directors No. 85 dated July 4, 2018)
- 1.3. National flags of Clubs participating in the Championship, KHL, FHR and Federal subjects of equal size located at a prominent place above the ice surface of the hockey rink of the Sports Facility. Forms, colors and the use of the national flags of Clubs participating in the Championship must comply with the laws of their respective countries.
- 1.4. At least two ice-resurfacing machines meeting modern technical requirements and subject to mandatory technical maintenance before the season start.
- 1.5. Scoreclock in accordance with the Rule Book of the Hockey Game. Exact and full name of the Championship must be visible on the scoreclock or at another noticeable location of the spectators seating. If displayed on the scoreclock, the Championship name must be demonstrated continuously or in the news ticker format during the Game. The text block must comply with the requirements of the KHL Marketing and Communications Regulations.
- 1.6. A technical device for making the audio signal (siren) connected to countdown chronometers in dressing rooms of teams and at the premises of Referee and Linesmen. The device is designed to inform about the countdown start, warm-up start and end, as well as appearance of teams on the hockey rink in the beginning of a Game and after intermissions (in accordance with the requirements of the KHL Sports Regulations).
- 1.7. At least two dressing rooms for Hockey Players equipped with comfortable furniture (chairs, tables, hangers, mirrors, stick racks, countdown chronometers, etc.), sufficient electric sockets, ventilation system and a hockey rink mockup, two floor fans with a diameter of at least 40 cm. The dressing rooms must be equipped with wireless Internet access system (Wi-Fi supporting the WPA2 Personal network security technology). Network identifier and access password shall be set by technical specialists of the Sports Facility in compliance with KHL requirements presented one (1) month prior to each season start (and are displayed to Hockey Players). Each dressing room area must be at least 70 m², excluding auxiliary adjacent premises:
(last updated on July 4, 2018. Minutes of meeting of CHL LLC Board of Directors No. 85 dated July 4, 2018)
 - a) shower stalls (wall mixers) in compliance with applicable construction standards and rules (at least five);
 - b) toilet cabins (at least three);
 - c) rooms for Coaches (area of at least 10 m²) equipped with comfortable furniture and hockey rink mockup, wireless Internet access system (Wi-Fi supporting the WPA2 Personal network security technology). Network identifier and access password shall be set by technical specialists of the Sports Facility in compliance with KHL requirements presented one (1) month prior to each season start (and are displayed to Coaches).
(last updated on July 4, 2018. Minutes of meeting of CHL LLC Board of Directors No. 85 dated July 4, 2018)
 - d) massage rooms (area of at least 8 m²) equipped with two massage tables; it is also recommended to allocate a room for visiting team doctor;
 - e) driers for sports uniform;
 - f) storing rooms;
 - g) specifically prepared areas (near the dressing room) for hockey skate sharpening and other technical procedures equipped with sufficient electric sockets and an exhaust

KHL TECHNICAL REGULATIONS

ventilation system;

h) driers properly certified by their manufacturer for 24 pairs of skates / gloves.

- 1.8. The sports area floor must be specifically covered to prevent damaging Hockey Players' skates.
- 1.9. A convenient seat on the grandstands at the center of the rink and conditions for video recording of the Games by visiting Club representatives, excluding the technical equipment required for the recording.
- 1.10. A separate room of a sufficient area for four (4) people — Chief Referees and Linesmen (for six (6) people during play-off). The room must be located as far as possible from dressing rooms of hockey teams and equipped with a ventilation system, shower, toilet, and provide for enough personal areas to change clothes (similar to personal areas for changing Hockey Players' clothes), hangers, a mirror, the rink mockup, TV set, a laptop connected to the TV set, wireless network coverage (WiFi with WPA2 Personal, the network ID and password required for access shall be set by technical specialists of the Sports Facility in compliance with the KHL requirements sent 1 month prior to start of each season and then such network ID and password shall be put up in the above room for the Officials' information), countdown meter, telephone connection with the room of the Ice Arena Video Goal Judge, exercycles in working order (2 pcs.), exercise mats (2 pcs.). The following products and items shall be in the above room: bottled (still) water, energy drinks (isotonic drinks), coffee, tea, fruits, sandwiches, chocolate, shampoo, towels, shoe laces (4 pairs), insulating tape (white and transparent), pizza upon completion of the Game (subject to Club's availability). Prior to start of the Game, the Club shall send a service-man to the above Officials' room to check that all listed above is in the room. Upon Chief Referee's request, the Club shall make it possible to view the recorded Game, including the recordings made by the Video Goal System cameras after the Game.
(last updated on July 4, 2019. Minutes of meeting of CHL LLC Board of Directors No. 96 dated July 4, 2019)
- 1.11. A room for the Officials' team to execute the Official Game Report equipped with the countdown timer, a laptop, printer, Internet access and means of communication to send the Official Game Report by electronic mail or fax to KHL.
(last updated on July 4, 2018. Minutes of meeting of CHL LLC Board of Directors No. 85 dated July 4, 2018)
- 1.12. Ten workplaces for Statistic Teams located at the top of central sectors of the grandstands on the Players' Bench side. The workplaces shall be equipped with desks and chairs, electric sockets, seven laptops provided by the Club for each Game, Internet connection at a speed of at least 1 Mbit/sec for each device. A wired connection must be used for Internet access. Redundant communication channels must be provided for Internet access. Wi-Fi can be used only as a redundant communication channel. Allocating the Statistic Team workplaces and different areas of the Sports Facility and (or) changing the location of workplaces during the season must be approved by KHL in writing.
(last updated on July 4, 2019. Minutes of meeting of CHL LLC Board of Directors No. 96 dated July 4, 2019)
- 1.13. A Statistic Team member workplace for direct text broadcasts via Internet to the KHL website with full view of the rink, Internet access with a guaranteed speed of at least 1 Mbit/sec, electric sockets, a desk and a chair. The Statistic Team member workplace for direct text broadcasts via Internet to the KHL website may be located separately from major workplaces of the Statistic Team. Redundant communication channels must be provided for Internet access and a laptop provided by the Club, as well as telephone or radio communication with all other workplaces of the Statistic Team.
- 1.14. The workplace of the KHL partner's Statistic Team member located next to the members of Statistic Teams equipped with a desk and a chair, electric sockets, Internet access with a guaranteed speed of at least 1 Mbit/sec for each connected device. A wired or Wi-Fi connection must be used for Internet access. Redundant communication channels must be provided for Internet access. Changing the location of a workplace of the KHL partner's Statistic Team member during the season must be approved by KHL in writing.

KHL TECHNICAL REGULATIONS

1.15. Designated locations for two teams of duty medical personnel and parking area for two ambulance vehicles for the entire period of the Game. Location of the duty medical personnel teams must be designated by a flag or banner (size: 30 x 40 cm) that must be visible from all spectators' seats. Medical personnel teams shall be located close to the rink, the storage area for medical equipment and maintenance gate for ice resurfacing machines, not higher than the second row of the Sports Facility grandstands. There shall be no obstacles along the route of the medical team to the rink during the Game.

(last updated on July 4, 2018. Minutes of meeting of CHL LLC Board of Directors No. 85 dated July 4, 2018)

1.16. Sports Facility Medical Station:

- a) shall be easy to approach by spectators and ambulance crews;
- b) shall have doors and passages of enough width to bring in stretchers or wheelchairs;
- c) shall be equipped with bright lighting, ventilation, heating, air-conditioning system, electrical sockets, cold and hot water, potable water, washbasin and toilet, internal and external telephone communications;
- d) shall be equipped in compliance with Appendix No. 8 to the Order of the Ministry of Health of the Russian Federation No. 134n "On the procedure of organizing the provision of medical aid to people engaged in physical training and sports (including preparation and holding of physical training and sports events), including the procedure for medical examination of people who want to be engaged in sports training, physical training or go in for sports at organizations and/or reach qualifying standards of tests within the scope of the All-Russian Physical and Sports Complex "Ready for Labor and Defense"" dated March 1, 2016. At the Sports Facilities where foreign KHL Clubs hold "home" Championship Games, the medical station must be equipped in compliance with the national legislation;
- e) shall provide qualified medical personnel working according to a pre-approved schedule.

1.17. Clear signs of direction to the Medical Station making it possible to use the shortest route to the Medical Station from any location at the Sports Facility.

1.18. Doping Control Station located close to the rink and Hockey Players' dressing rooms with necessary instruments for collecting samples from Hockey Players under control. Passage to the Station must be specifically covered to protect hockey skates. There must be a No Trespassing sign on the door of the Doping Control Station. Spectators and Mass Media Representatives shall not have access to the Doping Control Station. The Doping Control Station must be equipped in compliance with the requirements of the KHL Medical Regulations.

1.19. Designated seats at the stands (at least ten (10)) for disabled people and at least ten (10) seats for their accompanying persons ensuring barrier-free environment and the respective passages equipped with special appliances (ramps, elevators) for free movement and access of persons with disabilities related to supporting-motor system, using wheelchairs, as well as an equipped toilet cabin for this category of people, including a washbasin with a pedal-type mixer, a mirror above the washbasin located at the right height, hinged handrails at the flush toilet area, a paper tissue or towel container, open-type toilet paper holder or dispenser, a liquid soap container, a wastebasket. Height must be convenient for this category of people. External ramps must have handrails taking account of technical requirements for stationary supporting devices. On the territory adjacent to the Sports Facility, there must be a designated parking area for at least ten cars transporting disabled people.

(last updated on July 4, 2018. Minutes of meeting of CHL LLC Board of Directors No. 85 dated July 4, 2018)

1.20. Deleted.

(last updated on July 4, 2019. Minutes of meeting of CHL LLC Board of Directors No. 96 dated July 4, 2019)

1.21. Seats for KHL and FHR executives, Club managers if the respective preliminary request is submitted no later than 24 hours before the Game start.

1.22. Separate working premises for KHL representatives equipped with telephone and fax

KHL TECHNICAL REGULATIONS

communications, a copying machine and computer with a printer, a TV set with an option to view direct broadcast of the Game. The computer shall be connected to the Internet.

1.23. A separate room with full view of the rink for the Ice Arena Video Goal Judge, Game Inspector, and Club technician at the top level of the Sports Facility. The room shall be equipped with the following technical devices:

- a) a DVD player with internal hard drive, function of simultaneous TV signal recording and playback on the monitor. If TV broadcast is not available — video signal from the arena's camera designed for the video scoreclock/display cube;
- b) two monitors for TV signal and the Video Goal System with display size of at least 22 inches;
- c) three-way telephone communication with the respective headset (headphones and microphone) for conversations between the Chief Referee, the Arena Video Goal Judge, and the KHL Video review specialist;
- d) three-way communication channel with the respective headset (headphones and microphone) for conversations between the Chief Referee, the Arena Video Goal Judge, and the KHL Video review specialist;
- e) a technical option to display the Game time on the monitor of the Arena Video Goal Judge when viewing controversial events from cameras of the Video Goal System;
- f) a control button for the orange lamp installed on the referee desk;
- g) hand stopwatch.

1.24. The Video Goal System that shall ensure the following:

- a) receipt of video data from two hockey goal nets using color video cameras for full view of the goal net area by cameras inside, behind and above the goal net. Video cameras and servers must support the following output video signal parameters: resolution of at least High Definition 1080i-p and frame rate no less than 50 fps (no less than 50 movement phases). The goal camera is installed in the upper part of the back vertical goal post. The camera lens must be located at the junction of the upper internal arc and the central goal post and be directed downwards to the goal line. The camera view must cover the goal line and lower parts of goal posts. The goal line on the picture must be direct. The camera behind the goal net must be installed sharp in the center on the outer side of the board. The lens must be at the height of 20–25 cm above the upper part of the board. The camera view must cover the goal net and the rink section of one meter around the goal-crease area. The camera above the goal net must be installed so that the camera view covers the goal net, the goal-crease area, the rink section of one to two meter behind the goal net, one to two meter on either side of the goal net and the rink section up to nearest sections of faceoff circles in front of the goal net. The location of cameras behind and above the goal net, as well as cameras inside the goal net, must comply with the images and layouts specified in Appendix 5 to the KHL Technical Regulations.

Note. Since February 1, 2020, all ice arenas where home games of the KHL Clubs are held shall be additionally equipped with four (4) video cameras of High Definition 1080i-p, at least 50 fps (at least 50 movement phases), with zoom, which shall be located so that four cameras can view the whole surface of the rink together with the protective netting behind the boards and the Players' benches and Penalty Boxes while each of four cameras shall have a view a quarter of the ice rink (two cameras for one half of the ice rink). As agreed with the Department of Competitions, the Clubs may use other technical systems (television stations, etc.) or cameras with zoom to provide a view of the surface of the rink together with the protective netting behind the boards and the Players' benches and Penalty Boxes. Signals of additional cameras shall be transmitted to the Officials' desk, the monitor of the Ice Arena Video Goal Judge and the video review room at the FHR office;

(last updated on July 4, 2019. Minutes of meeting of CHL LLC Board of Directors No. 96 dated July 4, 2019)

- b) availability of a video to view and make decision on scoring a goal. Signals of cameras shall be transmitted to the Officials' desk, the monitor of the Ice Arena Video Goal Judge and the

KHL TECHNICAL REGULATIONS

video review room at the FHR office;

(last updated on July 4, 2019. Minutes of meeting of CHL LLC Board of Directors No. 96 dated July 4, 2019)

- c) recording of video retrieved from cameras to a computer hard drive or DVD disc; the recording must contain the timecode of the clock system;
- d) individual archiving and transmission of video recording of controversial events related to the goals or Major penalties from cameras of the Video Goal System viewed by Ice Arena Video Goal Judge during the Game upon request of the Chief Referee that shall be sent via Internet to the KHL server in compressed H.264 or AVCHD format after the end of each “home” Game;

(last updated on July 4, 2019. Minutes of meeting of CHL LLC Board of Directors No. 96 dated July 4, 2019)

- e) The Ice Arena Video Goal Judge shall have an option with the assistance of the host Club specialist to quickly rewind and view any required fragment of the recorded game video (controversial goals);
- f) uninterrupted power supply throughout each Game;
- g) reliable operation in the triplex mode when recording, viewing channels in real-time mode and recorded videos from the archive can be performed simultaneously;
- h) availability of additional High Definition 1080i-p video cameras with at least 50 fps (at least 50 movement phases) on blue lines (at least 2 cameras on each blue line) that must support 4–6X optical zoom. The signal from cameras shall be transmitted to the officials’ desk, the Ice Arena Video Goal Judge’s monitor and the video review room at the FHR office. These cameras shall be located so that neither structures of the Sports Facility nor Players, teams’ representatives, Officials, spectators may, with their positions, obstruct or otherwise obscure the view to review disputable situations;

(last updated on July 4, 2019. Minutes of meeting of CHL LLC Board of Directors No. 96 dated July 4, 2019)

- i) the image of the Video Goal System in the Sports Facility shall be transmitted to the video review room at the FHR office to display online;

(last updated on July 4, 2019. Minutes of meeting of CHL LLC Board of Directors No. 96 dated July 4, 2019)

- j) availability of a triplex communication channel for conversations between the Chief Referee, the Ice Arena Video Goal Judge and the Chief Specialist in the video review room at the FHR office.

(last updated on July 4, 2019. Minutes of meeting of CHL LLC Board of Directors No. 96 dated July 4, 2019)

1.25. The officials’ desk must be equipped with the following elements:

- a) red lamp with a flashing light to indicate commercial breaks installed on a vertical post 1 meter above the officials’ desk level and equipped with a control button on the desk;
- b) orange lamp of the Video Goal System located within the visibility zone of on-ice referees;
- c) a 22-inch monitor installed on the officials’ desk for viewing controversial events synchronized with the equipment in the Ice Arena Video Goal Judge and video cameras on blue lines (to implement the procedure of a detailed viewing upon a Coach’s request, of Chief Officials’ consultations and review of disputable situations in compliance with Article 87 of the KHL Sports Regulations);

(last updated on July 4, 2019. Minutes of meeting of CHL LLC Board of Directors No. 96 dated July 4, 2019)

- d) additional communication channel with the respective headset (headphones and microphone) for conversations between the Chief Referee and the Ice Arena Video Goal Judge;

- e) deleted;

(last updated on July 4, 2018. Minutes of meeting of CHL LLC Board of Directors No. 85 dated July 4, 2018)

KHL TECHNICAL REGULATIONS

- f) the information board control device with an option to connect the TV Broadcaster (for synchronizing TV broadcasts with the clock of the Sports Facility);
 - g) hand stopwatch;
(last updated on July 4, 2018. Minutes of meeting of CHL LLC Board of Directors No. 85 dated July 4, 2018)
 - h) referee whistle;
(last updated on July 4, 2018. Minutes of meeting of CHL LLC Board of Directors No. 85 dated July 4, 2018)
 - i) a telephone with the respective headset (headphones and microphone) for conversations between the Chief Referee, the Ice Arena Video Goal Judge and the Chief Specialist in the video review room at the FHR office and for communication of the Officials' team with the Service Company.
(last updated on August 27, 2019. Minutes of meeting of CHL LLC Board of Directors No. 98 dated August 27, 2019)
- 1.26. An individual video camera for non-stop panoramic recording of the Game, including Players' Benches and Penalty Benches, from the moment when teams start the warm-up until the moment when teams leave the rink at the Game end. The recorded video shall be stored by the Club for 14 days after the respective Game and presented to KHL immediately upon request. The video camera shall support HD format and perform HD recording (technical parameters of the camera shall be agreed with the TV Project Department of CHL LLC prior to its purchasing).
- 1.27. Press Center for Accredited Mass Media Representatives — specifically allocated separate premises close to Mass Media areas equipped with the following:
(last updated on July 4, 2018. Minutes of meeting of CHL LLC Board of Directors No. 85 dated July 4, 2018)
- a) at least twenty (20) workplaces, and during the Championship Second Stage – at least thirty (30) workplaces equipped with extension cables for at least 2 electric sockets for one workplace;
(last updated on July 4, 2019. Minutes of meeting of CHL LLC Board of Directors No. 96 dated July 4, 2019)
 - b) five (5) workplaces of the 20 workplaces shall be equipped with a wired Internet connection (including no less than 2-meter-long Ethernet cable with the RJ-45 connector for each workplace);
 - c) two (2) TV sets with display size of at least 40 inches for viewing direct broadcast of the Game in case it is prepared;
 - d) a multifunctional device (printer, copier and scanner) supporting color printing in A4 format from removable media, copying and scanning to the removable media; two (2) packs of A4 paper;
 - e) a laptop or a desktop computer with Internet access (with a guaranteed outgoing stream speed of at least 50 Mbit/sec) connected to the above-mentioned multifunctional device;
 - f) an information stand for the latest information for Mass Media including, but not limited to:
 - a sign with the Wi-Fi network identifier (SSID) and password (A5 format, at least 10 signs);
 - a sign with phone numbers of press officers (or Club employees performing these functions) of both Clubs;*(last updated on July 4, 2018. Minutes of meeting of CHL LLC Board of Directors No. 85 dated July 4, 2018)*
 - g) lockers for temporary storage of photographers' equipment — at least five (5) lockers with minimum width of 575 mm and depth of 500 mm;
(last updated on July 4, 2018. Minutes of meeting of CHL LLC Board of Directors No. 85 dated July 4, 2018)
 - i) hot and cold water dispenser, disposable tableware, tea, coffee, sugar and other meals for

KHL TECHNICAL REGULATIONS

mass media representatives at the discretion of the Club;

(last updated on July 4, 2019. Minutes of meeting of CHL LLC Board of Directors No. 96 dated July 4, 2019)

- j) 2 waste bins and 2 cloth hangers;
 - k) Game report holders (the A4 size) – 2 pcs. (one holder is in the press-center, another one is outside the press-center – for groups of clients who have no admission to the press-center).
(last updated on July 4, 2019. Minutes of meeting of CHL LLC Board of Directors No. 96 dated July 4, 2019)
- 1.28. The following areas and premises shall be covered by the wireless Internet access network (Wi-Fi network supporting WPA2 Personal secure access technology):
- a) guaranteed outgoing traffic speed of at least 50 Mbit/sec must be provided at the Press Center, at the Press Box, in the areas for accredited photographers at the grandstand and along the rink perimeter, as well as in the mixed zone, flash interview area, and in the room for press conferences throughout the entire period of operation; free use option shall be provided to accredited mass media representatives (mandatory SSID is KHL_Media);
(last updated on July 4, 2019. Minutes of meeting of CHL LLC Board of Directors No. 96 dated July 4, 2019)
 - b) guaranteed outgoing traffic speed of at least 20 Mbit/sec must be provided at the premises, boxes and in areas allocated to KHL, as well as in the room for the Official Game Report execution with the free use option for KHL employees at least 3 hours prior to and 2 hours after KHL Games or other events to be held at the Sports Facility jointly with KHL (mandatory SSID is KHL_OOF);
Access passwords for the above-mentioned networks shall be set by the Sports Facility specialists and provided to the KHL Information Technology Department no later than 10 business days prior to the season start and shall be changed during the season upon KHL request.
- 1.29. Press Box for Accredited Mass Media Representatives:
- a) located at the Sports Facility grandstand on the opposite side from the Players' Bench (not higher than the box level) to ensure full view of the rink and Players' Benches;
 - b) there shall be at least 30 equipped workplaces and at least 50 during the Championship Stage Two;
 - c) all workplaces shall be equipped with desks and extension cables for at least 2 electric sockets for one workplace;
 - d) five (5) workplaces (15 workplaces during the Championship Stage Two) shall be equipped with a wired Internet connection (including no less than 2-meter-long Ethernet cable with the RJ-45 connector for each workplace).
- 1.30. Soundproof room for press conferences with the following equipment:
- a) seating for at least 30 Mass Media representatives;
 - b) a presidium desk with a solid front panel, 4 soft chairs, desk name plates, tribune for the press officer of the host Club;
 - c) audio equipment and a microphone for each presidium seat (or a conference system for at least 4 speakers);
 - d) one (1) wireless microphone for questions from Mass Media representatives;
 - e) glasses and still water bottles for speakers and Mass Media representatives. If KHL has a Championship sponsor/partner/advertiser of the "Drink" product category, water for the press conferences shall be provided to KHL by the sponsor/partner/advertiser;
 - f) KHL advertising banner of at least 2x4 meter size.
If a Sports Facility construction and architecture make it impossible to hang the 2x4 meter advertising banner, the banner size shall be agreed with KHL.
- 1.31. Mixed zone for meetings of Accredited Mass Media Representatives with Hockey Players and team Coaches as close as possible to dressing rooms of participating teams. The mixed zone shall be spacious enough for all interested Mass Media representatives and easily accessible from media areas. If a Sports Facility construction and architecture make it impossible to

KHL TECHNICAL REGULATIONS

- organize a mixed zone at a location equally convenient for participating teams, an additional mixed zone may be organized to meet the above-mentioned requirements. The mixed zone shall be equipped with a TV set with display size of at least 40 inches for viewing direct Game broadcast (if it is prepared), as well as KHL advertising banner of at least 2x3 meter size. If a Sports Facility construction and architecture make it impossible to hang the 2x3 meter advertising banner, the banner size shall be agreed with KHL.
- 1.32. Flash interview area located close to the rink entrance for teams if the Sports Facility design makes it possible. The flash interview location shall be equipped with the KHL advertising banner of at least 2x3 meter size, while the upper edge of the banner must be located at a height no less than 2.5 meters above the floor, as well as three electric sockets (and a special “TV” sign). If a Sports Facility construction and architecture make it impossible to hang the 2x3 meter advertising banner, the banner size shall be agreed with KHL.
- 1.33. Areas at the Sports Facility grandstands for at least ten (10) accredited photographers marked with the “PHOTO” sign; workplaces for accredited photographers along the rink perimeter, except for areas where spectators’ seats are located closely to the rink. Areas along the rink perimeter for at least ten (10) photographers must be marked with the “PHOTO” signs on boards from the stand side. In the areas near the rounded corners of the hockey rink, two (2) wired Internet connections must be available (a socket and at least 2-meter-long Ethernet cable with the RJ-45 connector for each connection), and the sockets must be installed separately (at different rounded corners).
- 1.34. Sufficient sites for positioning TV cameras (at least twelve (12) sites) and mini-cameras (at least six (6) sites). The leading camera site shall be located on the opposite side from the Players’ Benches. One of the mini-camera sites shall be located between the Players’ Benches of both teams. In addition, positioning of two TV cameras above the guest and host goal nets must be provided for, as well as access of TV company employees to the technical floor for installing the cameras. TV camera sites where contact with spectators is probable must be isolated by mobile fence barriers with a belt or otherwise.
(last updated on July 4, 2018. Minutes of meeting of CHL LLC Board of Directors No. 85 dated July 4, 2018)
- 1.35. Sports commentator sites (no less than two) located at the same level with cameras on the side where major cameras are located. Each commentator site must provide for two seats, electric sockets, lighting, phone with an option to make long-distance calls, Internet access (Wi-Fi), ISDN line for organizing the commentator channel.
- 1.36. At least three suspensions for original sound microphones above the hockey rink (center + 2 zones) and one suspension for original sound microphones over the center of the central grandstand, as well as equipment to transmit audio broadcast via 1–2 commentator channels from commentator sites and all suspensions for original sound microphones.
- 1.37. Sites for OB Vehicles and remote transmitting devices (antennas, transmitters, etc.) with an option to connect them to stable and redundant power supply systems. The capacity of the electric board at SPTVTS to connect OB Vehicle to the primary power supply system of the Sports Facility shall be no less than 50 kW. There shall be connectors for 125A and 63A connections (main and standby connections). TV transport entry must be organized if agreed with the Club beforehand (OB Vehicle, mobile radio station, mobile satellite station, mobile electric power station and auxiliary equipment). The TV transport shall be parked near SPTVTS.
- 1.38. Connection of the following TV areas to the standby system of power supply of the Sports Facility:
- 1) OB Vehicle;
 - 2) camera installation sites;
 - 3) sports commentator sites;
 - 4) mixed zone;
 - 5) TV studio;
 - 6) premises for press conferences and interviews.

KHL TECHNICAL REGULATIONS

- 1.39. The TV studio location shall be agreed with KHL;
- 1.40. The average level of horizontal illuminance of the ice hockey rink surface during competitions (the “Game” mode) without TV broadcasting Ehor.av. — no less than 750 lx, horizontal illuminance uniformity factor Emin./Eav. — no less than 0.7.
(last updated on July 4, 2018. Minutes of meeting of CHL LLC Board of Directors No. 85 dated July 4, 2018)
- 1.41. The average level of vertical illuminance at the height of 1.5 meters above the ice rink surface towards the leading TV camera during competitions with color TV broadcasting Evert.av. — no less than 2500 lx; towards secondary TV cameras Evert.av. — no less than 1800 lx (the illuminance compliance with the requirements of this paragraph must be ensured within 3 years, i.e. before the 2021/2022 season start).
(last updated on July 4, 2018. Minutes of meeting of CHL LLC Board of Directors No. 85 dated July 4, 2018)
- 1.42. The vertical illuminance uniformity factor towards the leading camera Emin./Eav. — no less than 0.8 and Emin./Emax. — no less than 0.65; the horizontal illuminance uniformity factor Emin./Eav. — no less than 0.8.
The vertical illuminance uniformity factor towards other TV cameras Emin./Eav. — no less than 0.6 and Emin./Emax. — no less than 0.4.
(last updated on July 4, 2018. Minutes of meeting of CHL LLC Board of Directors No. 85 dated July 4, 2018)
- 1.43. The average level of vertical illuminance of first eight rows of the grandstands towards the rink center during color TV broadcasting — no less than 40% of Evert.av of the ice rink towards the leading TV camera.
(last updated on July 4, 2018. Minutes of meeting of CHL LLC Board of Directors No. 85 dated July 4, 2018)
- 1.43.1 The light pulsation factor of light sources shall be no more than 1 %.
(last updated on July 4, 2018. Minutes of meeting of CHL LLC Board of Directors No. 85 dated July 4, 2018)
- 1.44. Modern light sources with color rendering index Ra of at least 80 and color temperature of at least 5600 K for lighting the ice rink surface.
- 1.45. Balanced Internet connection at SPTVTS and at OB Vehicle equipment location (RJ-45 sockets) for TV purposes with a guaranteed outgoing stream speed of at least 20 Mbit/sec and no less than 5 Mbit/sec for the standby channel. Traffic from the IP addresses that are used for operation via these channels shall not be filtered with firewalls or translated using the NAT mechanism. IP addresses must be available within Internet. Technical parameters of the Internet connection and the mobile number of the Club (Sports Facility) technical officer shall be stored in an envelope by the Sports Facility head’s secretary.
- 1.46. Continuous lighting in the Game mode during 60 minutes 2 hours prior to the Game start to setup video signal of TV cameras to meet the requirements of the KHL partner; the lighting mode shall not be changed during the pregame warm-up and Game intermissions; lighting in the Game mode for 20 minutes after the final buzzer. Should the hockey rink lighting be changed for the purpose of a pregame show or team roster presentation, the lighting shall be switched to the Game mode no later than six minutes before the Game start.
- 1.47. Stationary or extended tunnels (or other protective structures, except for nets) through which Players and Officials enter the ice to prevent physical contact of Players, Officials, Coaches and team personnel with supporters, as well as hitting Players, Officials, Coaches and team personnel with items thrown from the grandstands.
- 1.48. Video surveillance system installed pursuant to the terms and procedures of the Law making it possible to efficiently and fully control and record the situation in the areas adjacent to the Sports Facility, security check areas and Sports Facility entrances, at internal premises of the Sports Facility, at grandstands and in the ice rink. The video surveillance system shall be capable to operate in a manual and preset mode, store recorded data, process the resulting images, print out the images (stop-frame). The video cameras shall support high resolution

KHL TECHNICAL REGULATIONS

making it possible to identify objects in the picture.

The video surveillance system shall support continuous recoding:

- a) of the “away” sector from the moment when supporters enter the “away” Club supporters’ sector before the Game to the moment when they leave the sector after the Game end. The recorded video shall be stored by the Club no less than one month after the respective Game and presented to KHL immediately upon request;
- b) of the fan sector from the moment when supporters enter the fan sector of the host Club supporters to the moment when host fans leave the sector after the Game end. The recorded video shall be stored by the Club no less than one month after the respective Game and presented to KHL immediately upon request;
- c) the entrance area of the Chief Referees and Linesmen dressing room from the moment when the Officials enter the dressing room before the Game to the moment when they leave the dressing room after the Game end. The recorded video shall be stored by the Club no less than one month after the respective Game and presented to KHL immediately upon request;
- d) the entrance area of the Ice Arena Video Goal Judge from the moment when the Ice Arena Video Goal Judge enters the room before the Game to the moment when the Judge leaves the room after the Game end. The recorded video shall be stored by the Club no less than one month after the respective Game and presented to KHL immediately upon request;
- e) all sectors of the arena’s grandstands. The recorded data shall be stored by the Club for at least one month. Images (stop frames with time and date stamps) of all arena’s grandstands on the 30th minute of the Game retrieved from the video surveillance system cameras shall be forwarded to KHL within 12 hours after the end of each Game. The procedure and methods for presenting the images shall be regulated by the KHL Security Department issued before each season start.

(last updated on July 4, 2018. Minutes of meeting of CHL LLC Board of Directors No. 85 dated July 4, 2018)

- 1.49. Working premises for the competition organizer and coordinating bodies (committees, commissions) established to ensure public order and security during competitions at their respective venues; the premises shall be connected to the video surveillance system.
- 1.50. Premises for employees of the federal security service and bodies of internal affairs. When allocating premises for the above-mentioned bodies, foreign Clubs shall be guided by their national legislation.
- 1.51. Stationary walk-through metal detectors shall be installed at all entries to the Sports Facility selected for the Championship Games.
- 1.52. Automated access control system shall be installed at all spectator entrances to the Sports Facility intended to hold the Championship Games (integrated with the access control e-ticketing systems).
- 1.53. Emergency lighting at the Sports Facility in good working order.
- 1.54. Ice maker (or provide ice in a special temperature-resistant container) in the team dressing room area for medical purposes.
- 1.55. Navigation system (noticeable sign boards and signages) in two languages (national language of the country where the Sports Facility is located and English), including designations of all areas and premises that shall be used during the Championship Games, as well as passages to them for spectators, Mass Media Representatives, Hockey Players, Coaches, Officials, medical personnel, and Sports Facility personnel.

In the lobby of each spectator entrance to the Sports Facility, seating plans with indicated sectors shall be available.

(last updated on July 4, 2018. Minutes of meeting of CHL LLC Board of Directors No. 85 dated July 4, 2018)

- 1.56. The STM System installed and connected to power supply and required communications.
(last updated on August 27, 2019. Minutes of meeting of CHL LLC Board of Directors No. 98 dated August 27, 2019)

KHL TECHNICAL REGULATIONS

2. During the Regular Championship and play-off games, KHL Clubs must ensure proper maintenance of boards and safety glass shields. There shall be no contamination due to puck hits, fractures, cracks, etc. on boards and shields. Boards and shields shall be cleaned and polished (puck and skate marks) before every Game.
(last updated on July 4, 2018. Minutes of meeting of CHL LLC Board of Directors No. 85 dated July 4, 2018)
3. During the Regular Championship and play-off games, KHL Clubs must provide a group of technical personnel having neat appearance and wearing uniform clothes. The technical personnel shall have a set of tools for ice rink maintenance, board and safety glass maintenance, repair and replacement.
4. During the Regular Championship and play-off games, KHL Clubs must provide a group of technical personnel on skates (Appendix 9 to the KHL Sports Regulations) to collect pucks on the ice after pregame warm-up and clean ice during advertisement breaks. The personnel shall wear uniform clothes, have neat appearance, and have containers (buckets) for pucks, cleaning tools (spades, containers for snow).
5. The host Club must maintain the Players' Benches area in proper order during the Game. Wet cleaning shall be performed before and after warm-ups and during intermissions between Game periods.
6. The host Club shall restrict access to team dressing room area to prevent the presence of unauthorized persons there from the moment Club teams enter the Sports Facility to the moment when they leave the Sports Facility territory after a Championship Game or training session. During the above-mentioned period of time, access to the dressing room area shall be granted only to Hockey Players and team representatives who take part in the Game, Officials (if the Officials' room is located in that area), KHL representative according to Appendix 4 to the KHL Technical Regulations and additional KHL requirements, Game Inspector, Game Commissioner, Doping Control Inspector who collects samples.
7. The host Club must make sure that no unauthorized persons have access to technical areas adjacent to ice rink board during the Game or pregame warm-up. Access to the above-mentioned areas shall be granted only to Hockey Players and team representatives who take part in the Game, Sports Facility employees who maintain the ice rink, press photographers in accordance with their accreditation for certain sites, mini TV cameraman within a fixed site, official KHL representatives (Commissioner, Inspector, President, Vice-Presidents, KHL department directors), disabled persons and employees ensuring public order and security during the Game. However, the above-mentioned persons, excluding photographers, mini TV cameraman and disabled persons, may not approach the board closer than 1 meter (if it is possible to ensure from the technical point of view).
8. The host Club shall provide cloakrooms in the adjacent territory of the Sports Facility where spectators can leave their items that are prohibited to carry on to the Sports Facility.
9. The host Club shall maintain the lost and found department at the Sports Facility with the respective navigation signages.
10. During the period of 45 minutes before the Game start and 15 minutes after its end, the host Club shall provide spectators with wireless Internet access (Wi-Fi); minimum access speed at peak load shall be no less than 256 Kbit/sec per 1 user without limiting the volume of transferred data.
11. The host Club must ensure that mobile communication networks are available at the Sports Facility and take measures to maintain and improve the quality of mobile phone and Internet communications to provide stable and uninterrupted service to spectators even if the Sports Facility is full.
12. The host Club must provide an option to pay using bank cards at all points of sale at the Sports Facility.
(last updated on July 4, 2018. Minutes of meeting of CHL LLC Board of Directors No. 85 dated July 4, 2018)
13. At least one ATM must be installed in the Sports Facility lobby so that spectators can access it.
(last updated on July 4, 2018. Minutes of meeting of CHL LLC Board of Directors No. 85 dated

KHL TECHNICAL REGULATIONS

July 4, 2018)

14. The host Club must ensure that the KHL's contractor that provides communication services is able to provide means of communication to deliver direct broadcasts of KHL events and organize remote operation of the KHL and FHR officials' department. The ability to provide communication services means the following in these Regulations:
 - 1) granting access to the KHL contractor to organize communication services, including access to lay communication cables using technical premises and constructions of the Sports Facility that are designed for such laying of cables;
 - 2) allocating a site for the Contractor's equipment and means of communication.

(last updated on July 4, 2018. Minutes of meeting of CHL LLC Board of Directors No. 85 dated July 4, 2018)

CHAPTER 2. SAFETY ARRANGEMENTS

Article 4. General safety provisions

1. Ensuring the safety of teams, Hockey Players, Coaches, Club executives and other officers, Officials, Commissioners, Inspectors, KHL official representatives, Mass Media Representatives, spectators, and other persons during the Championship Games or other Championship events is based on the existing regulatory and legal framework at the location of each Championship Game or another KHL event, local regulatory acts of KHL on ensuring safety when holding Games.
2. Security during a Championship Game or another Championship event shall be ensured by the host Club unless KHL has established a different security procedure for a certain KHL event.

Article 5. Responsibility for safety and security arrangements

1. The host Club is responsible for ensuring security and safety during a Championship Game or another Championship event unless KHL has established a different security procedure for a certain event.
2. In addition to ensuring safety and security when holding a Championship Game or another Championship event, the respective Clubs must take security measures throughout the entire period of staying at the location of the Game, including meeting and sending off the visiting team and its supporters, Officials' teams, Commissioners, Inspectors, and KHL officers.
3. When playing a "home" Game, the host Club must take all the necessary measures to ensure proper safety and security during the Game in accordance with the national legislation of the countries whose Clubs take part in the Championship and the requirements of the KHL Technical Regulations.
4. The activities of Club officers with respect to safety and security during the Championship Games or other Championship events are coordinated by the head of the KHL Security Department and performed in close cooperation with law-enforcement agencies.
5. Each Club must have a fulltime deputy head of security responsible for ensuring safety and security. The employee shall have the following major functional duties:
 - 5.1. Interaction with law-enforcement agencies and other government authorities with respect to ensuring security of the Championship Games;
 - 5.2. Establishment of coordinating bodies (committees, commissions) to ensure public order and security during competitions at their respective venues;
 - 5.3. Ensuring security when playing "home" Championship Games, including the security of Hockey Players, Coaches, Club representatives, Officials, Commissioners, Inspectors, KHL representatives, Mass Media representatives, spectators and other persons at the respective Game location;
 - 5.4. Organization of security measures throughout the entire period of stay at the location of the Championship Game, including meeting and sending off the visiting team and its supporters, Officials' teams, Commissioners, Inspectors, and KHL officers;
 - 5.5. Organization of efficient interaction to ensure security during the Championship Games with the employees responsible for ensuring the security of other KHL Clubs;

KHL TECHNICAL REGULATIONS

- 5.6. Organization of interaction with supporters with respect to ensuring security;
- 5.7. Ensuring the compliance of the Club's memorabilia and support accessories with the requirements of the KHL Technical Regulations and selecting locations for their placement at the Sports Facility when playing "home" Games;
- 5.8. Organization of interaction and collaboration with the Sports Facility administration with respect to its technical infrastructure, "away" sector arrangement, development of ticket programs for the Championship Games, and other issues in order to improve safety and security during the Championship Games;
- 5.9. Organization of and participation in the development of Club programs aimed at improving the security level and public order, spectators' compliance with the Code of Conduct during the Championship Games;
- 5.10. Organization of measures to ensure safe operation of the Club;
- 5.11. Organizing and providing briefings to managers of private security agency, security services, control and administration services that perform security activities at Sports Facilities where the Championship Games are played so that the above-mentioned agencies can ensure high-quality performance of tasks relating to the security and safety of the Championship Games in compliance with the requirements of the KHL Technical Regulations.
6. The Club employee responsible for organizing the security must comply with qualification requirements and be evaluated by KHL. Qualification requirements and the evaluation regulations shall be developed by the Security Department. The evaluation dates and its regularity shall be determined by KHL. Based on the evaluation results, the employee receives a qualification certificate that confirms he can perform measures to ensure security during the Championship Games.
7. Any decision of the host Club or the visiting Club on applying additional security measures during a Championship Game must be agreed with KHL in advance.

Article 6. Organization of measures to ensure security during the Championship Games

1. On the day of the Championship Game, in order to ensure its security in compliance with the KHL Technical Regulations, the employee of the host Club who is responsible for the organization of measures to ensure security shall manage the agencies of the respective Sports Facility that are engaged in the process of ensuring security and order. The employee's instructions must be performed by managers and employees of security agencies, control and administration agencies, volunteers, etc.
2. The Club employee who is responsible for ensuring the security shall organize efficient interaction with the upper-level law enforcement officials and officers engaged in the enforcement of law and order during the Championship Game.
3. The Club employee who is responsible for ensuring the security shall provide assistance to the Commissioner or Inspector assigned by KHL to the Championship Game in performing his functions.
4. The host Club ensures:
 - a) safe stay of the visiting Club at the Sports Facility where the Championship Game is played and its adjacent territory from the moment of the visiting Club arrival to the Sports Facility for training or participating in the Game on Game day or on the eve of the Game, as well as safety of the sports equipment and other property of the visiting Club at the Sports Facility and its adjacent territory;
 - b) taking all the necessary measures to ensure security of the Chief Referees and Linesmen, including escort from the ice rink to the Officials' room to prevent any contact of unauthorized persons with the Chief Referees and Linesmen and ensure public order in the area close to the Officials' room before the Game start, during Game intermissions and after the Game end, as well as escorting reserve Officials from the Officials' room to the Officials' desk during the play-off game series;

(last updated on July 4, 2018. Minutes of meeting of CHL LLC Board of Directors No. 85 dated

KHL TECHNICAL REGULATIONS

July 4, 2018)

- c) taking all the necessary measures to ensure security of the Ice Arena Video Goal Judge, including organizing the guard post at the entrance to the premises of the Ice Arena Video Goal Judge throughout the entire period of the Judge's stay at the Sports Facility. The guard post grants access to the premises only to the Ice Arena Video Goal Judge, Inspector, Game Commissioner, and the Club technician who maintains the Video Goal System;
- d) proper control of spectators' passage to the Sports Facility grandstands in accordance with duly executed official documents (tickets, season passes, accreditations, invitations, etc.) so that on the Game day no person who uses obviously falsified documents (mismatch of color, size, illustration, paper structure, text, etc.) can enter the Sports Facility. Presence of spectators at the grandstands in excess of the prescribed seat capacity of the Sports Facility (individual spectator seats) is strictly prohibited;
- e) proper control of spectators' passage to the Sports Facility with respect to ban on carrying items and substances inside the Sports Facility that are prohibited by the Code of Conduct at the Sports Facility (Appendix 6 to the KHL Technical Regulations);
- f) proper control of spectator's compliance with the Code of Conduct at the Sports Facility in order to prevent and suppress incidents and disorder, throwing items and substances to the grandstands and ice rink, to spectators, Hockey Players, Coaches, Officials, Club representatives, Sports Facility representatives, law enforcement officers, competition organizer's officials, and other negative behavior. The exception is throwing caps onto the ice by fans if during one Game of the Championship a player of the playing teams scores 3 (hat-trick) or more goals. Throwing caps onto the ice under these circumstances is adherence to the world hockey tradition and is not dangerous for participants of the Game;
- e.1) access control around the Sports Facility for holders of the KHL Certificates in compliance with the KHL Certificate Provision (Appendix 4 to the KHL Technical Regulations), for KHL accredited persons, for persons under the League's lists to access to separate areas of the Sports Facility, and other access control provided by the KHL;
(last updated on July 4, 2019. Minutes of meeting of CHL LLC Board of Directors No. 96 dated July 4, 2019)
- g) security during after-game press conferences and safety of its participants eliminating the possibility of visiting the press conference by people who have no duly executed accreditation;
 - g.1) security and control of access to the Press Box for the accredited mass media representatives;
(last updated on July 4, 2019. Minutes of meeting of CHL LLC Board of Directors No. 96 dated July 4, 2019)
 - g.2) security and control of access to the press-center for the accredited mass media representatives;
(last updated on July 4, 2019. Minutes of meeting of CHL LLC Board of Directors No. 96 dated July 4, 2019)
- h) security and control of access to mixed zones designed for meetings of Accredited Mass Media Representatives with Hockey Players and Coaches, as well as during meetings of Accredited Mass Media Representatives with Hockey Players and Coaches in team dressing rooms after the Championship Game;
- i) security and control of access to TV camera sites and sites for video recording by team employees;
- j) the required amount of technical equipment and specialists trained to quickly deactivate pyrotechnics, respond during an emergency (fire, smoke spread, etc.);
- k) security and control of access to the Doping Control Station, including organizing a guard post at the entrance to the Doping Control Station from the end of the second Game period to the moment when the last sportsman leaves the Doping Control Station. The guard post shall grant access to the above-mentioned premises only to authorized persons specified in Appendix 11 to the KHL Medical Regulations. The guard post is organized only if the doping control procedure is performed during the Game;

KHL TECHNICAL REGULATIONS

(last updated on July 4, 2018. Minutes of meeting of CHL LLC Board of Directors No. 85 dated July 4, 2018)

- 1) take all the necessary measures to ensure the security of the Penalty Box and the Officials' team, as well as adjacent areas (technical zones and passages, stands) taking account of using video review procedures upon a Coach's request. Only the Officials' team, the Chief Referee, and Linesmen are allowed to access the Officials' box during the Game, including intermissions.

Article 7. High-risk Games

1. KHL may decide to assign a Championship Game to the high-risk category at its own discretion or upon a Club request if the Club has reason to expect that conflict situations may occur during the Game.
2. KHL shall send its Commissioners to the high-risk Games.
3. If a Championship Game is included in the high-risk category, the host Club shall take additional measures to ensure its safety and security and inform law-enforcement authorities about such a Game in a timely manner.
4. The Championship Game may be included in the high-risk category due to the following factors:
 - a) The Game is highly important from the sports point of view;
 - b) It is a Derby Game;
 - c) The Game is played between teams whose supporters are uncompromising opponents;
 - d) The number of "away" supporters that are expected to visit the Game is in excess of the number of tickets to be allocated to "away" supporters under these Regulations;
 - e) The Game has an international status;
 - f) There is information that certain circumstances may obstruct the normal course of the Game.
5. Should the Championship Game be included in the high-risk category, KHL is entitled to cancel organizing the "away" sector and revoke the right of the visiting Club to buy out Game entrance tickets for the Club's supporters. Entrance tickets for the specified sector shall be sold to the host Club supporters.

CHAPTER 3. SPECTATORS (SUPPORTERS)

(last updated on July 4, 2018. Minutes of meeting of CHL LLC Board of Directors No. 85 dated July 4, 2018)

Article 8. Responsibility

1. The Club shall organize interaction with its supporters and bear responsibility for their conduct during the Championship Games.
2. A spectator (supporter) shall be held liable for a violation of the applicable law of the country where the Club's "home" Game is played, Code of Conduct at the Sports Facility (Appendix 6 to the KHL Technical Regulations).

(last updated on July 4, 2018. Minutes of meeting of CHL LLC Board of Directors No. 85 dated July 4, 2018)
3. The Club shall publish the text of the Code of Conduct at the Sports Facility on its official website. Foreign Clubs shall publish the Code of Conduct at the Sports Facility in Russian and in English, as well as in the national language of their country. The Code of Conduct shall be published on the official website separately from other documents on a page that can be easily accessed by the website visitors.

(last updated on July 4, 2018. Minutes of meeting of CHL LLC Board of Directors No. 85 dated July 4, 2018)
4. The Club must display the text of the Code of Conduct (extract from the Code) at the Sports Facility where "home" Games are played, in the ticket office area, at the Sports Facility entrances, at the entrances to grandstands sectors, as well as organize broadcasting of the text at the Sports

KHL TECHNICAL REGULATIONS

Facility.

Article 9. Requirements to Clubs relating to interaction with spectators (supporters)

(last updated on July 4, 2018. Minutes of meeting of CHL LLC Board of Directors No. 85 dated July 4, 2018)

1. Each Club must have a fulltime employee responsible for the interaction with supporters, as well as an employee responsible for the interaction with spectators.
(last updated on July 4, 2018. Minutes of meeting of CHL LLC Board of Directors No. 85 dated July 4, 2018)
2. The Club shall organize interaction with spectators (supporters) in the following areas:
(last updated on July 4, 2018. Minutes of meeting of CHL LLC Board of Directors No. 85 dated July 4, 2018)
 - 2.1. Development and implementation of various programs (season passes, tickets, marketing, etc.) aimed at attracting spectators to the Championship Games, ensuring comfortable and safe environment for them at the Sports Facility.
(last updated on July 4, 2018. Minutes of meeting of CHL LLC Board of Directors No. 85 dated July 4, 2018)
 - 2.2. Interaction with supporter alliances aimed at organizing the Club team support during the Championship Games, including “away” Games, within the scope of these Regulations and Code of Contact at the Sports Facility.
 - 2.3. Interaction with the Club supporters whose residence is outside the region of the Club base, their information support, including ticket programs for both “home” and “away” Games of the Club.
 - 2.4. Organizing the Club supporters’ trips to “away” Games of the Championship.
 - 2.5. Participation of a Club employee in charge of supporter relations during “away” Games in order to ensure day-to-day interaction with the representatives of the host Club and law-enforcement authorities.
 - 2.6. Sales of tickets to “away” Games to the Club supporters.
 - 2.7. Ensuring comfortable and safe conditions for the visiting Club supporters at the Sports Facility: organizing the “away” sector, making it possible for visiting supporters to stay at the Sports Facility as part of a compact group, approval of the Club means of supporting in a timely manner, information support, etc.
(last updated on July 4, 2018. Minutes of meeting of CHL LLC Board of Directors No. 85 dated July 4, 2018)
 - 2.8. Development of the spectators’ (supporters’) behavioral philosophy when visiting the Championship Games and supporting their team.
(last updated on July 4, 2018. Minutes of meeting of CHL LLC Board of Directors No. 85 dated July 4, 2018)
 - 2.9. Taking all possible measures to prevent access of those spectators (supporters) who violate the public order and Code of Conduct at the Sports Facility to the Club Games.
(last updated on July 4, 2018. Minutes of meeting of CHL LLC Board of Directors No. 85 dated July 4, 2018)

Article 10. “Away” sector (sector for active support)

1. The “away” sector is a section of the Sports Facility grandstand (several sectors, a sector, part of a sector) where visiting Club fans and, optionally, supporters are located in a compact manner and separately from other spectators.
2. The “away” sector must be confined by security areas all around. The security areas (passages, stairs, several rows of vacant seats) are created to prevent close contact between the visiting teams’ supporters and host teams’ supporters, as well as supporters trespassing. The security areas shall be controlled by officers of the agencies that ensure order and security during the Game.
(last updated on July 4, 2018. Minutes of meeting of CHL LLC Board of Directors No. 85 dated July 4, 2018)

KHL TECHNICAL REGULATIONS

July 4, 2018)

3. The visiting Club is granted the right to buy out on a priority basis entrance tickets to the Championship Game for its supporters in the “away” sector in the amount of 3 % of the total number of spectator seats at the Sports Facility where the Game is played, as long as the request for buying out the above-mentioned entrance tickets is submitted no later than 48 hours before the Game start (24 hours for play-off series), and the tickets are purchased no later than 2 hours before the Game start.
No perfunctory approach is allowed when submitting the request by the visiting Club with respect to the number of entrance tickets for its supporters in the “away” sector (formal overstatement of the amount based on the 3 % quota; understatement of the amount; failure to submit the request). The visiting Club must have objective information on the number of its active supporters who intend to visit the “away” sector during the “away” Game of their team and reflect it in the request.
4. The “away” sector size shall comply with the requirements of the KHL Technical Regulations as to the number of tickets allocated to the visiting Club and security requirements. The host Club shall reserve additional seats in the “away” sector in the amount of 10 % of the number specified in the visiting Club request in case more unaccounted guest supporters arrive to the Game as long as the total number of tickets to the Game for guests does not exceed the number prescribed by the KHL Technical Regulations.
5. If the visiting Club fans appear in other sections of the stadium, the host Club must promptly take measures to move the fans to the “away” sector.
6. The host Club may reduce the “away” sector size based on the visiting Club request making sure the security requirements are met.
7. The host Club may increase the “away” sector size as compared to the size prescribed hereby based on commercial interests or agreements with the visiting Club making sure the security requirements are met.
8. If only a part of a Sports Facility sector is used as the “away” sector, it shall be located at the upper part of the grandstand, tier (no other spectators shall be seated behind the visiting team supporters).
9. The “away” and fan sectors must be located at the opposite grandstands.
10. Selling tickets to the host team supporters to the “away” sector is prohibited.
11. The host club must take measures to localize visiting team supporters throughout the territory of the Sports Facility: at canteens, smoking areas, public areas, stairs, passages. The measures may include changing the location of the “away” sector, adjustment of spectator flows within the Sports Facility area, changing the location of meal stations, entrances to the Sports Facility and so on.

Article 11. Memorabilia, means of supporting

1. During the Championship Games, spectators (supporters) may bring the following things to the Sports Facility and use them during the Game to support their Club:
(last updated on July 4, 2018. Minutes of meeting of CHL LLC Board of Directors No. 85 dated July 4, 2018)
 - a) scarfs, hats, clothes bearing the Club emblems;
 - b) memorabilia officially sold by Clubs.
2. The memorabilia owners must present it at the entrance to the Sports Facility.
3. Representatives of supporters’ alliances are allowed to use the following things as long as a responsible person is assigned to each of them:
 - a) drums with one membrane and open bottom, diameter of up to 60 cm and height of up to 40 cm, with standard drumsticks;
 - b) banners of various configurations provided that they are placed at the grandstands in the way that does not create inconveniences for other spectators watching the Game. Banners’ position in the Sports Facility shall be determined by a representative of the host Club who is

KHL TECHNICAL REGULATIONS

responsible for the Club security organization in consultation with the Sports Facility administration, senior law enforcement officer of the security control center during the Game and firefighting service representative. The banners shall be made of non-flammable materials (treated with special compounds) and have the appropriate fire safety certificates. The content of the banners shall be aimed only at supporting the Club and shall not contain offensive, obscene, provocative, defamatory texts, words, symbols, images;

(last updated on July 4, 2018. Minutes of meeting of CHL LLC Board of Directors No. 85 dated July 4, 2018)

- c) flags attached to a hollow plastic staff. The length of the staff cannot exceed 1.5 m. The flags shall be made of non-flammable materials (treated with special compounds) and have the appropriate fire safety certificates. The use of such flags is allowed in the “home” and “away” sectors. Images on the flags shall be aimed only at supporting the Club and shall not contain offensive, obscene, provocative, defamatory texts, words, symbols, images;

(last updated on July 4, 2018. Minutes of meeting of CHL LLC Board of Directors No. 85 dated July 4, 2018)

- d) means of supporting containing words and expressions in the official languages of republics of the Russian Federation or official languages of the countries whose Clubs participate in the Championship shall have a translation certified by the Club;
- e) means of supporting containing words and phrases in languages that are not specified in the previous item d must be notarized;
- f) means of supporting containing abbreviations and combinations of digits shall have a written explanation of the meaning of such abbreviations and combinations of digits certified by the Club;
- g) other means of Club supporting. The use of other means of supporting may be allowed by the joint decision of the organizer, Sports Facility administration and the senior law enforcement officer of the security control center of the Championship Game as long as the means of supportings meet security requirements and do not disturb spectators.

- 4. The number of drums, other means and methods of Club supporting, including team mascots, that are used by the visiting Club supporters, shall be determined by the host Club in advance and agreed with the Sports Facility administration, law enforcement agency center, firefighting service. In case of disagreement with the methods and the amount of means of supporting specified in the entrance ticket purchase request, the host Club shall inform the visiting Club respectively no later than 24 hours before the Game start (during play-off series — in a timely manner). No response to the request from the host Club means its approval to use the declared means and methods of supporting.

(last updated on July 4, 2018. Minutes of meeting of CHL LLC Board of Directors No. 85 dated July 4, 2018)

- 5. The owners of the above-mentioned means of Club supporting shall present them 1.5 hours before the Game to representatives of the host Club, Sports Facility administration, security control center and firefighting service for checking them for compliance with the requirements.

In the event of non-compliance with the requirements of this Article of the KHL Technical Regulations, as well as Code of Conduct by the Club supporters, any of the above-mentioned means of Club supporting may be banned.

- 6. Means of Club supporting during “home” Games (show programs, theme music, etc.) shall not:
 - a) be offensive, slighting, or discrediting with respect to the visiting Club and its supporters, and provoking their negative response and consequences;
(last updated on July 4, 2018. Minutes of meeting of CHL LLC Board of Directors No. 85 dated July 4, 2018)
 - b) use Nazi emblems, words or expressions, attributes and symbolics and extremist paraphernalia, as well as using emblems and symbols confusingly similar to them.

- 7. When preparing and performing a show, Clubs are prohibited to use pyrotechnical products, open fire, including cold and arc lamp projectors, fireworks, and other types of fire effects in the Sports

KHL TECHNICAL REGULATIONS

Facility before, during, and after the Championship Games. When ensuring safety and security, foreign Clubs shall apply this provision in accordance with their national legislation.

8. When preparing and performing a show, the host Club must ensure that officers and professionals (team mascot, show presenters, and other professionals who deal with spectators during the Game) do not commit any actions that incite supporters to violate the Code of Conduct at the Sports Facility or supporters' aggression or unrest at the Sports Facilities.

Article 12. Ticket program

1. The host Club shall maintain an electronic ticket system supporting online sales of tickets to all "home" Games regardless of the Sports Facility where the host Club plays. The used access control ticketing system should be integrated with the official KHL e-tickets distribution service.
 - 1.1. The Club shall provide KHL with information on the number of sold tickets at grandstands (sectors) of the Sports Facility automatically in the real-time mode.
(last updated on July 4, 2018. Minutes of meeting of CHL LLC Board of Directors No. 85 dated July 4, 2018)
2. When manufacturing entrance tickets, season passes, the host Club shall provide for several levels of protection to complicate their counterfeiting.
3. The entrance ticket, season pass shall contain the required information for its owner: Game name, Sports Facility name, date and time of the Game start, specify the grandstand, sector, row and seat, extracts from the Code of Conduct at the Facility relating to spectator's duties and items that are banned from bringing to and using at the Sports Facility.
4. At the ticket offices of the Sports Facility where the Championship Game is played, all the required information for spectators (supporters), including the supporters of the visiting Club, shall be available: specification of the "away" sector, availability of a certain Game entrance tickets for sale (at ticket offices or via the visiting Club). A separate ticket office must be assigned for the visiting Club supporters.
5. In the ticket office area must be placed Code of Conduct at the Sports Facility (extracts from the Code). Foreign Clubs shall place the Code of Conduct at the Sports Facility in Russian and in the national language of their country.
6. For supporters who live in others cities and countries KHL Clubs introduce the system of selling entrance tickets to "away" Games through the Club (through Club representative working at the "away" Game), taking into consideration that the visiting Club must be aware of the number of supporters planning to visit the "away" Game of the Club to submit objective data in the request for entrance ticket purchase.
7. Clubs develop the ticket and season pass program for the Championship Games taking account of the requirements for organizing the "away" sector.
8. Selling and distributing tickets to the "away" sector online is prohibited.
9. During the Game the host Club must ensure the security of Players, team representatives and Officials on the ice, in the Players' Bench and Penalty Box areas to prevent their physical contact with spectators. For these purposes, the host Club shall take all the required measures, including reserving the required number of seats close to Players' Benches and Penalty Boxes, as well as in the areas where spectators may enter the ice rink. These seats are allocated to representatives of the structures ensuring public order and security.
10. The host Club interacts with the law enforcement bodies, develops and implements measures to prevent selling tickets to the Championship Games by institutions and persons that are not officially contracted by the Club to sell the tickets. The Club may restrict the number of tickets sold to one person.
11. Upon the visiting Club's request, the host Club must provide 20 free entrance tickets to the Championship Game, if the request is submitted no later than 24 hours before the Game.
 - 11.1. Tickets for spectators may be of various categories depending on location in the Sports Facility.

VIP Box

A separate confidence room in the VIP area of the Sports Facility, it is equipped with seats to view

KHL TECHNICAL REGULATIONS

the Game both inside the room and outside on the side of the grandstands.

Category One

Tickets for the seats in the central sections of tier 1 in the Sports Facility but no lower than row 6.

Category Two

Tickets for the seats in the Sports Facility's sections adjacent to the central ones and located in tier 1 but no lower than row 6.

Category Three

Seats in tier 1 in the Sports Facility which are not adjacent to a fan sector and are not located on the grandstands behind the goal net.

Category Four

All other seats which are not among Categories One, Two and Three.

(last updated on July 4, 2019. Minutes of meeting of CHL LLC Board of Directors No. 96 dated July 4, 2019)

12. The host Club must provide to KHL or to persons specified by KHL 25 Category Three entrance tickets, 50 Category Two entrance tickets, 50 Category One entrance tickets, a separate VIP-box for at least ten (10) seats, on the long side of the hockey rink (if the box is not provided by the Sports Facility project, additional 10 Category One entrance tickets) without charge, 10 passes to the secure car park of the Sports Facility.
. Tickets of all categories shall be provided by the KHL for the seats located in the lower tiers of the Sports Facility, but no lower than row 6, with unobstructed view of the hockey rink.
If the allocated tickets are not demanded, KHL shall inform Clubs respectively: during the Regular Championship no later than 48 (forty-eight) hours prior to the Game and during play-off — no later than 24 hours before the Game.
(last updated on July 4, 2019. Minutes of meeting of CHL LLC Board of Directors No. 96 dated July 4, 2019)
13. The host Club must ensure priority right to purchase the following number of tickets by KHL or persons specified by KHL:
 - a) one hundred and thirty (130) tickets of the categories selected by KHL in total (Categories One, Two, Three) to each Game of the Regular Championship, as long as the Club receives KHL's request for such tickets no later than fourteen (14) calendar days before the respective Game start;
 - b) seventy-five (75) tickets of the categories selected by KHL in total (Categories One, Two, Three) to each play-off Game, as long as the Club receives KHL's request for such tickets no later than twenty-four (24) hours after determining the date of the respective Game start.
(last updated on July 4, 2019. Minutes of meeting of CHL LLC Board of Directors No. 96 dated July 4, 2019)
14. Price of tickets to the "away" sector shall not be higher than the price of tickets to adjacent or similar sectors of the arena.

CHAPTER 4. FINAL PROVISIONS

The KHL Technical Regulations come into effect from the moment they are approved by the CHL LLC Board of Directors and shall remain effective until the approval of the new KHL Technical Regulations.

KHL TECHNICAL REGULATIONS

Appendix 1

(last updated on August 27, 2019. Minutes of meeting of CHL LLC Board of Directors No. 98

dated August 27, 2019)

**CERTIFICATE
of compliance of the Sports Facility and Hockey Club
with the Technical Regulations
of the Kontinental Hockey League Championship –
Russian Ice Hockey Championship among Men’s Teams
of season _____**

_____ 20 _____

(full name of the Hockey Club)

2. Sports Facility name _____

Address: _____ Owner _____

Document on the grounds of which the Sports Facility is used by the Club _____

(name, number, date of signature, effective term)

Year of commissioning _____,

Date of the latest major repairs _____

Seating capacity (seats for spectators) _____

3. Training rink availability _____

| Name | Actual condition |
|---------------------------------|---|
| Entrance to the Sports Facility | Access control _____ Stationary walk-through metal detectors _____ Location of text of the Code of Conduct at the Sports Facility (extract from the Code) _____ _____ |
| Access control ticketing system | Manufacturer: _____ Number of turnstiles of the access control system: _____ Access control system (barcode, MiFare, alternative): _____ Manufacturer of the access control system: _____ Access terminal equipment (manufacturer and reading options): _____ Supporter identification system manufacturer: _____ Types of readable tickets: paper / electronic / mobile QR codes / contactless cards / other Types of readable season passes: paper / plastic / electronic / mobile QR codes / contactless cards / other Types of readable tickets to boxes: paper / plastic / electronic / mobile |

KHL TECHNICAL REGULATIONS

| Name | Actual condition |
|---|--|
| | QR codes / contactless cards / other |
| Video surveillance system | Existing video surveillance system (the number of cameras) Adjacent territory _____ Entrances _____ Public spaces (lobby, canteens, passages, stairs, etc.) _____ Premises under the grandstands Premises under the grandstands _____ Grandstands _____ “Away” sector _____ Fan sector _____ Entrance to the room of Chief Referees and Linesmen _____ Entrance to the room of Ice Arena Video Goal Judge _____ Compliance of video surveillance system with the Regulations requirements _____ |
| STM System | Number of locators: _____ Server: _____ Switching device: _____ UPS: _____ Router: _____ |
| Board system of the hockey rink | Manufacturer _____ Commissioned on _____ Rink dimensions, m _____ Total length of the perimeter alongside the board, m _____ Board section length, m _____ Board height, m above ice _____ Protection of board advertisement _____ Kick plate, cm _____ Shelf, cm _____ Injury-safe cover _____ |
| Ice surface with clearly visible official marking (in accordance with the Rule Book of the Hockey Game) | Ice quality _____ Marking quality _____ Compliance of marking colors with the RAL table (red — 3020, blue — 5005, light blue — 5012) _____ Water preparation equipment _____ |
| Facilities for ice cleaning and puck collection | Availability of spades _____ Availability of containers for snow _____ Availability of containers (buckets) for puck collection _____ |
| Game goals and goals for pregame warm-up | Buffer stuffing (white color) _____ Bottle fixture _____ Compliance of the goal color based on the RAL table _____ Elastic lockers (minimal length 20 cm) _____ Size of inserts for lockers, cm _____ Depth in the goal post for locker, cm _____ Net (white color) _____ Side posts and a horizontal bar (red color) _____ |

KHL TECHNICAL REGULATIONS

| Name | Actual condition |
|--|---|
| Strobes or lights with the strobe function above the goal net | Availability _____ |
| Video cameras of the Video Goal System | <p>Video cameras inside the goal net in protective cases (white color) _____</p> <p>Manufacturer _____</p> <p>Video cameras behind the goal net _____</p> <p>Manufacturer _____</p> <p>Video cameras above the goal net _____</p> <p>Manufacturer _____</p> <p>Video cameras on the blue lines _____</p> <p>Location of video cameras on the blue lines _____</p> <p>Manufacturer _____</p> <p>Compliance of the video camera signal parameters (resolution no less than HD 1080i or 1080p; frame rate no less than 50 fps (movement phases)) _____</p> <p>Compliance of the Video Goal System images with the Regulations requirements _____</p> <p>Location of Video Goal System video cameras _____</p> <p><i>Note. The Club shall send to the League a video made by all video cameras of the Video Goal System prior to start of the next season</i></p> |
| Safety glass/acryl shield | <p>Height behind the goal net, cm _____</p> <p>Height alongside the boards, cm _____</p> <p>Gaps between safety glass sections (no more than 5 mm) _____</p> <p>Safety stuffing to the safety glass/acryl shield height _____</p> <p>Rounding to the safety glass/acryl shield height _____</p> <p>Sections / inserts between safety glass along the entire perimeter of the hockey rink to the height of the safety glass/acryl shield _____</p> |
| Safety shield / safety glass canopy separating Hockey Players on the Players' Benches and in Penalty Boxes from spectators | <p>Safety shield behind the Players' Benches and Penalty Boxes _____</p> <p>Distance between Players' Benches, m _____</p> <p>Safety shield at the edges of the Players' Benches and Penalty Boxes _____</p> <p>Sections / inserts between safety glass to the safety glass height _____</p> |
| Netting over the safety glass to separate spectators behind the goals from the hockey rink | Height (no less than 10 m) _____ |

KHL TECHNICAL REGULATIONS

| Name | Actual condition |
|--|---|
| Ice resurfacing machines (at least two) | Number _____ Firm _____ Year of manufacture _____ Technical maintenance certificate _____ |
| Container for puck cooling | Availability _____ |
| Scoreclock _____ | Availability, manufacturer _____ Compliance with the Regulations requirements _____ |
| Scoreclock control device | Availability _____ Compliance with the Regulations requirements _____ |
| Scoreclock control device | Availability _____ Option to connect the Broadcaster equipment _____ |
| Video scoreclock (display cube) | Availability, manufacturer _____ Compliance with the Regulations requirements _____ |
| Technical device for producing audio signal at the arena which is used by the Referee during games | Audio signal (siren) availability _____ |
| Championship name | Availability _____ Location _____ |
| Technical device for producing audio signal (siren) | Integration with countdown clocks in dressing rooms and in the room of Chief Referees and Linesmen _____ _____ |
| Flags | Number _____ Size _____ Location _____ |
| Dressing rooms for Hockey Players of the host team | Number of dressing rooms _____ Area (no less than 70 m ²) _____ Location with respect to: Officials' room _____ visiting team dressing room _____ Availability of the following items in the dressing room: electric sockets within the accessible area (no less than five) _____ ventilation system _____ hockey rink mockup _____ countdown clock _____ furniture _____ stick rack _____ special cover to protect hockey skates _____ |

KHL TECHNICAL REGULATIONS

| Name | Actual condition |
|--|---|
| Availability of equipment and premises adjacent to the dressing rooms of Hockey Players of the host team | Availability: shower room with cold and hot water (at least five shower heads) ____ toilet cabins (at least, three) ____ rooms for Coaches (at least 10 m ²) ____ hockey rink mockup in the Coaches' room ____ furniture in the Coaches' room ____ massage room (at least 8 m ² , two massage tables) ____ drier for sports uniform ____ drier for 24 pairs of skates / gloves ____ ice maker / temperature-resistant container ____ two floor fans (minimum diameter 40 cm) ____ storing rooms ____ equipped area for skate sharpening and other technical procedures equipped with sufficient electric sockets and an exhaust ventilation system ____ _____ Area for quick warm-up ____ Wireless Internet access (Wi-Fi) with password information _____ |
| Dressing rooms for Hockey Players of the visiting team | Number of dressing rooms ____ Area (no less than 70 m ²) ____ Location with respect to: Officials' room ____ host team dressing room ____ Availability of the following items in the dressing room: electric sockets within the accessible area (no less than five) ____ ventilation system ____ hockey rink mockup ____ countdown clock ____ furniture ____ stick rack ____ special cover to protect hockey skates ____ |
| Availability of equipment and premises adjacent to the dressing rooms of Hockey Players of the visiting team | Availability: shower room with cold and hot water (at least five shower heads) ____ toilet cabins (at least, three) ____ rooms for Coaches (at least 10 m ²) ____ hockey rink mockup in the Coaches' room ____ furniture in the Coaches' room ____ massage room (at least 8 m ² ; two massage tables) ____ drier for sports uniform ____ drier for 24 pairs of skates / gloves ____ ice maker / temperature-resistant container ____ two floor fans (minimum diameter 40 cm) ____ storing rooms ____ equipped area for skate sharpening and other technical procedures equipped with sufficient electric sockets and a ventilation system ____ area for quick warm-up ____ Wireless Internet access (Wi-Fi) with password information _____ |

KHL TECHNICAL REGULATIONS

| Name | Actual condition |
|---|---|
| Entry of teams to the ice rink | Distance _____ Special cover to protect hockey skates _____ Separate or joint _____ |
| Entry of Officials to the ice rink | with entry of the rival team _____ with entry of the Chief Referees and Linesmen _____ Tunnels / other constructions _____ Distance _____ Special cover to protect hockey skates _____ Tunnels / other constructions _____ Separate or joint with entry for team(s) _____ |
| Site for the Game video recording by the visiting team operator | Location _____ Equipment _____ |
| Video camera for the Game video recording by the host team operator | Availability _____ Compliance of the video camera technical specifications with the Regulations requirements _____ |
| Room for Chief Referees and Linesmen | Location _____ Equipment: bidirectional communication with the room of Ice Arena Video Goal Judge _____ ventilation system _____ shower, toilet _____ personal areas for changing clothes _____ hangers _____ mirror _____ hockey rink mockup _____ TV set _____ laptop _____ countdown clock _____ Availability of two stationary bicycles near the Officials' room _____ |
| Officials' desk | Equipment: red lamp of the advertisement break _____ orange lamp of the Video Goal System _____ monitor with display size of 22 inches _____ additional communication channel for headset _____ scoreclock/display cube control device _____ hand stopwatch _____ Official's whistle _____ availability of a triplex communication phone with headset (headphones and microphone) _____ |
| Room for the Official Game Report Execution and Officials' team | Location _____ Equipment: laptop _____ printer _____ Internet access _____ facsimile communication _____ furniture _____ countdown clock _____ |

KHL TECHNICAL REGULATIONS

| Name | Actual condition |
|--|---|
| Workplace of the Statistic Team member for direct text broadcasts via Internet | Location _____ Personal computer _____ Internet access _____ Phone/Radio communication with workplaces of the Statistic Team (if the workplace is located separately) _____ |
| Workplaces of the Statistic Team members | Number (at least ten) _____ Location _____ Laptops (at least seven) _____ Availability of wired Internet access _____ Availability of a redundant Internet access channel _____ |
| Workplace of the Statistic Team member of the KHL partner | Location _____ Availability of wired Internet access _____ Availability of a redundant Internet access channel _____ |
| Sites for medical personnel and parking area for two ambulance vehicles | Location _____ Number _____ Site designation _____ Flag / banner (size 30 × 40 cm) _____ Location of the car parking area _____ Location of the transport board trolley during the Game _____ |
| Sports Facility Medical Station | Location _____ Working hours information on the door _____ Doors and passages of enough width to bring in stretchers or wheelchairs _____ Availability of standard medical station equipment, including cardio-synchronous defibrillator, manual artificial respirating unit _____ Location signs _____ Map of evacuation of Hockey Players from ice rink, spectators to Medical Station and ambulance cars approved by the KHL Medical Department _____ |
| Doping Control Station | Location _____ Special floor cover to protect hockey skates _____ No Trespassing sign on the door _____ Availability of combined premises: waiting room and toilet _____ Equipment compliance with the requirements of the Medical Regulations _____ Access organization _____ |
| Medical room of the host Club | Location _____ Equipment compliance with the requirements of the KHL Medical Regulations _____ |
| Working premises for competition organizer or coordinating bodies | Location _____ Video surveillance system output _____ |

KHL TECHNICAL REGULATIONS

| Name | Actual condition |
|--|--|
| Premises for employees of the federal security service or bodies of internal affairs | Location _____ _____ |
| Access to the Sports Facility using KHL Certificates | Availability of the KHL Certificate Provision _____ Entrance selection (Staff entrance No.) _____ |
| Category Two seats | Number _____ Seat location _____ |
| Category One seats | Number _____ Location _____ Access organization _____ |
| Seats for disabled people | Location _____ Number (at least ten + the same number of seats for accompanying persons) _____ Site designation _____ Access organization _____ Barrier-free access _____ Ramps, elevators _____ Toilet cabins _____ Parking lot _____ Location _____ Parking lot sign (for at least 10 cars) _____ |
| Possibility to demonstrate advertisement products (car, etc.) | Grandstand location _____ Lobby location _____ |
| Room for kids | Location _____ Capacity _____ |
| Separate working premises for KHL representatives | Location _____ Equipment: telephone _____ fax _____ copy machine _____ computer with a printer and Internet access _____ TV set _____ furniture _____ wireless Internet access (Wi-Fi) in the KHL seat area _____ at the grandstand (box) _____ |

KHL TECHNICAL REGULATIONS

| Name | Actual condition |
|--|---|
| Separate room for the Ice Arena Video Goal Judge equipped with the Video Goal System | Location _____ Area (m ²) _____ System availability _____ Equipment: bidirectional communication with the Officials' desk and the room of Chief Referees and Linesmen _____ availability of a triplex communication phone _____ _____ individual telephone communication with the Officiating Department _____ technical equipment for recording and viewing the Game and controversial events _____ hand stopwatch _____ full view of the ice rink _____ compliance of video camera image quality with the Regulations requirements _____ _____ |
| Press Center for Mass Media representatives | Equipment: Number of workplaces _____ Multifunctional device and A4 paper _____ Laptop (computer) _____ Internet access, outgoing stream speed (no less than 50 Mbit/sec) _____ Place for receiving information materials _____ Organization of Mass Media representatives entry _____ _____ Wireless Internet access (Wi-Fi) _____ Signs with information on Wi-Fi access _____ TV set (display size no less than 40 inches) _____ Lockers for temporary storage of photographers' equipment _____ Hot and cold water dispenser, disposable tableware, tea, coffee, sugar _____ _____ Waste bins, cloth hangers _____ Co-located / not co-located with the room for press conferences _____ _____ Information stand _____ Navigation signs _____ |
| Press Box | Grandstand location _____ Equipped seats (no less than 30 + 20 for play-off) _____ Desks _____ Electric sockets _____ Organization of Mass Media representatives entry _____ Wireless Internet access (Wi-Fi) _____ Wired Internet access _____ Navigation signs _____ |

KHL TECHNICAL REGULATIONS

| Name | Actual condition |
|---|---|
| Room for press conferences | Location _____ Capacity (no less than 30) Equipment: Flag / banner (size 2 × 4 cm) _____ Audio equipment of the presidium _____ Wireless microphone _____ Furniture _____ Wireless Internet access (Wi-Fi) _____ Navigation signs _____ |
| Mixed zone for meetings of Accredited Mass Media Representatives with Hockey Players and team Coaches | Location _____ Number _____ Flag / banner (size 2 × 3 cm) _____ TV set (display size no less than 40 inches) _____ Wireless Internet access (Wi-Fi) _____ Navigation signs _____ |
| Area for accredited photographers' equipment at the grandstands | Number (at least ten) _____ Location _____ PHOTO signs _____ Wireless Internet access (Wi-Fi) _____ Navigation signs _____ |
| Flash interview area | Location _____ Number _____ Flag / banner (size 2 × 3 cm) _____ Electric sockets (at least three) _____ TV sign for the sockets _____ Wireless Internet access (Wi-Fi) _____ Navigation signs _____ |
| Areas for accredited photographers alongside the hockey rink perimeter | Location _____ PHOTO signs _____ Navigation signs _____ |
| “Away” sector | Location with respect to the fan sector of the host _____ _____ Grandstand _____ Sector _____ |
| Host fan sector | Location with respect to the “away” sector _____ _____ Grandstand _____ Sector _____ |
| Sites for stationary TV cameras | Number (at least 12) _____ Location _____ Equipment _____ Barriers _____ |

KHL TECHNICAL REGULATIONS

| Name | Actual condition |
|---|--|
| Sites for TV mini cameras | Number (at least four) _____ Location _____ Equipment _____ Barriers _____ |
| Seats for two TV cameras above the goal net | Number (at least two) _____ Location _____ Equipment _____ |
| TV studio premises | Location _____ Area _____ Equipment _____ |
| Commentary positions | Number (at least two) _____ Location _____ Equipment: long distance telephone _____ electric sockets _____ lighting _____ Internet access _____ ISDN lines for organizing the commentator channel _____ _____ |
| At least three suspensions for original sound microphones above the hockey rink (center + 2 zones) and one suspension for original sound microphones over the center of the central grandstand | _____ _____ _____ _____ _____ |
| Equipment to transmit audio broadcast via 1–2 commentator channels and at least three suspensions for original sound microphones above the hockey rink (center + 2 zones) and one suspension for original sound microphones over the center of the central grandstand | _____ _____ _____ _____ _____ |
| Sites for OB Vehicles | Location _____ Equipment _____ |

KHL TECHNICAL REGULATIONS

| Name | Actual condition |
|---|---|
| SPTVTS electric board | Power _____ 125A connection _____ 63A connection _____ |
| The average level of horizontal illuminance of the ice hockey rink surface (during competitions without TV broadcasting Ehor.av.) | |
| The average level of vertical illuminance at the height of 1.5 meters above the ice rink surface towards the leading TV camera (during competitions with color TV broadcasting) | |
| The vertical illuminance non-conformity factor Emin./Eav. | |
| Light source | Color rendering index _____ Color temperature _____ |
| Internet access channel for SPTVTS and OB Vehicle (speedtest.khl.ru) | Incoming channel speed (no less than 20 Mbit/sec): _____ Outgoing channel speed (no less than 5 Mbit/sec): _____ Availability of a redundant channel _____ (no less than 5 Mbit/sec) _____ |
| Emergency lighting | Availability _____ _____ |
| Wireless Internet access (Wi-Fi) | |
| Availability of cellular operators | MegaFon _____ Beeline _____ MTS _____ Tele2 _____ |
| Cloakroom | |
| Lost and found department | |
| Plans of grandstands | Presence and number _____ Location _____ |

KHL TECHNICAL REGULATIONS

| Name | Actual condition |
|---|---|
| ATMs | Presence and number _____ Bank names _____ |
| Site for the equipment and means of communication of the KHL contractor for organizing communication services | Availability _____ |

3. Availability of regulating documents

| | |
|--|--|
| Permit for the commissioning of the object | |
| Sports Facility certificate | |
| Ownership rights registered in the Unified State Register | |
| Certificate of the Sports Facility readiness for operation | |
| Certificate of inspection by state control (supervision) authority, by local government oversight of legal entity and self-employed person (Russian Federation Ministry of Civil Defence and Emergency Response) | |

KHL TECHNICAL REGULATIONS

Ice rink layout

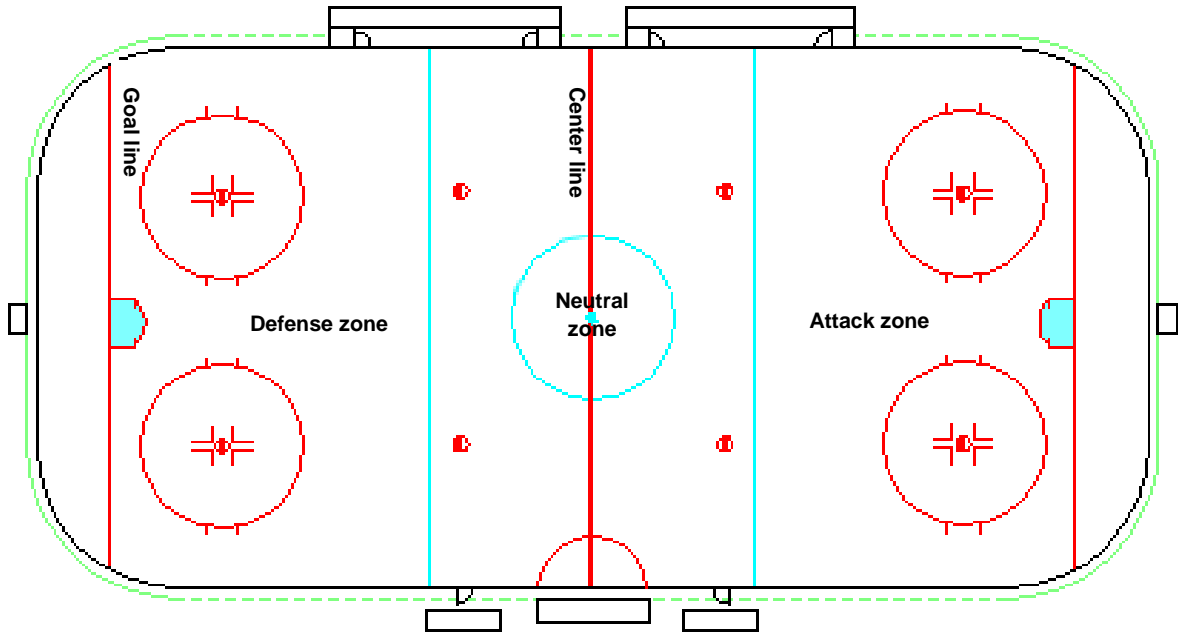

4. Additional information on infrastructure

| | |
|--|---|
| Airport | Location _____ _____ |
| Railway station | Location _____ _____ |
| Customs procedures | _____ _____ _____ |
| Travel time | From airport _____ From railway station _____ |
| Provision of a bus to the visiting team | Model _____ |
| Conditions of access by vehicle / entrance for teams | Separate entrances to the Sports Facility _____ |
| | Public entrance to the Sports Facility _____ |
| Conditions of access by vehicle / entrance for Chief Referees and Linesmen | Separate entrance to the Sports Facility _____ |
| | Common with team(s) entrance to the Sports Facility _____ |

KHL TECHNICAL REGULATIONS

| | |
|--|---|
| Availability of guarded parking lots | For teams _____ For Officials _____ For spectators _____ For VIP persons _____ |
| Junior Team Junior Team Sports Facility Sports school Sports school Sports Facility | Name _____ Name _____ Name _____ Name _____ |

Club representative _____ / _____ /
Seal

Sports Facility representative _____ / _____ /
Seal

Representative of the Service Company acting on behalf of the KHL (I hereby confirm availability and serviceability of the STM System equipment) _____ / _____ /
Seal

CERTIFICATE OF READINESS

_____ of (Sports Facility name)

for Game No. _____ of the Kontinental Hockey League Championship – Russian Ice Hockey Championship among Men’s Teams of season _____ “ ___ ” _____ 20___

between teams _____

1. _____ (Sports Facility name) is ready

for the above-mentioned Game in accordance with the Regulations requirements.

2. The available material and technical resources, equipment, facilities are sufficient to hold the hockey Game (Appendix to the Certificate).

3. Holding the above-mentioned Game has been agreed with the following authorities: General Administration for Traffic Safety, medical service, firefighting service, law enforcement authorities.

4. To ensure the safety and security of the Game participants and maintenance of public order, the required forces of the law enforcement authorities and security service have been mobilized.

5. A control and administration service has been engaged to interact with spectators.

6. The staff and engaged organizations responsible for holding the Game have been briefed with respect to their official duties and occupational health and safety compliance by the Sports Facility directorate on “ ___ ” _____ 20___.

Signatures:

Hockey Club Head _____ (Full name)

Sports Facility Head _____ (Full name)

“ ___ ” _____ 20___

“ ___ ” _____ 20___

Stamp

Stamp

KHL TECHNICAL REGULATIONS

Appendix

to the Certificate of Readiness _____
of (*Sports Facility name*)

READINESS

_____ of (*Sports Facility name*)

for Game No. ____ of the Kontinental Hockey League Championship –
Russian Ice Hockey Championship among Men's Teams of season _____
“ ____ ” _____ 20 ____

IS CONFIRMED BY:

| No. | Name | Position | Full name | Signature |
|-----|--|---------------------------------|-----------|-----------|
| 1. | Availability of the required operating personnel of the Sports Facility | | | |
| 2. | Availability of the required forces to maintain public order | | | |
| 3. | Availability of the control and administration service | | | |
| 4. | Readiness of the event participants, Officials | | | |
| 5. | Readiness for medical support of the Game and doping control | Chief Physician of Competitions | | |
| 6. | Readiness to receive spectators (grandstands, routes of spectators and competition participants evacuation, lobbies, entrances, etc.) | | | |
| 7. | Readiness of staff and meals stations to serve spectators | | | |
| 8. | Reliability of the building construction units | | | |
| 9. | Readiness of power supply and lighting systems | | | |
| 10. | Readiness of communications, alerting systems, scoreclock, radio and text broadcasting system in case of emergency and persons allowed to use the microphone | | | |
| 11. | Readiness of the ventilation system | | | |
| 12. | Readiness of water supply and sewer systems | | | |
| 13. | Readiness of the Commandant's service | | | |
| 14. | Readiness of the firefighting system | | | |
| 15. | Compliance of the sports equipment and tools with the rules of competitions | | | |

CERTIFICATE OF INSPECTION

_____ of (Sports Facility name)
 as of “ _____ ” _____ 20____, _____ hour(s)
 Inspection venue: _____
 _____ (Sports Facility address)

This Certificate is executed for the preparation to Game No. _____ of the Kontinental Hockey League Championship — Russian Ice Hockey Championship among Men’s Teams of season _____

We have inspected the arena’s entrances, lobby, boxes, arena, public meals stations, room space, and perimeter of the building _____

_____ of (Sports Facility name)

During the inspection, we have determined the following:

1. The Sports Facility is equipped with external and internal water supply for firefighting purposes.
2. The firefighting system is in good order and complies with the applicable legislation.
3. Duty of the volunteer fire brigade has been organized in the Sports Facility territory.
4. Evacuation routes are in proper order and under control during the Game by the security service _____ (organization name)

_____ and ensure safe and prompt evacuation of people in case of an emergency in accordance with the evacuation plan.

5. Unused premises of the arena will be closed and guarded during the Game.
6. Internal and external site security is ensured by _____

_____ (organization name)

7. Examination of spectators at the entrance to _____ (Sports Facility name) before the event shall be performed using _____ (metal detectors — stationary, mobile, etc.)

8. Automobile transport access to _____ (Sports Facility name) is ensured by the Federal Authority for Road Traffic Safety _____ (district name) and the security service of _____ (Sports Facility name) in accordance with issued passes.

9. During the inspection of _____ (Sports Facility name),

in particular, the main entrance, arena, lobby, boxes, public meals stations, roof spaces, perimeter of _____ (Sports Facility name),

as well as parked cars, by the security service, law enforcement authorities and cynologists, no items resembling improvised explosive devices or toxic substances have been found.

10. Two teams of qualified doctors and ambulance cars equipped in compliance with established standards are on duty.

KHL TECHNICAL REGULATIONS

| Title | Signature | Printed name |
|---|------------------|---------------------|
| Representative of the State Firefighting Service | | |
| Representative of the emergency paramedics | | |
| | | |
| Chief Physician of Competitions | | |
| Head of the Security Service of the Sports Facility | | |
| Specialist of the Cynology Center of the Ministry of Internal Affairs | | |
| Responsible representative of law enforcement authorities at the Game | | |
| Deputy security head of the Club | | |

(last updated on July 4, 2018. Minutes of meeting of CHL LLC Board of Directors No. 85 dated July 4, 2018)

KHL Certificate PROVISION

KHL Certificates are issued to KHL representatives, KHL Club representatives, Officials for the performance of their official and other duties during the Championship Games and training sessions at the Sports Facilities where KHL Championship Games are held.

The KHL Certificate does not grant the right to take seats at the grandstands to which tickets and season passes are sold. As an exception, the host Club may decide to let KHL Certificate owners take spectator seats if the arena’s grandstands are not full.

All KHL Certificates are issued after registration by KHL and must be returned to KHL during the dismissal according to established procedure.

The effective term is specified in the KHL Certificate.

KHL may specify or supplement details of access to certain areas and premises of the Sports Facility by means of separate orders before the season start and during the season.

KHL Certificates are divided in the following categories

1. Certificates of KHL representatives and KHL Officials (2 types: VIP and Standard)

VIP KHL Certificate (for KHL representatives)



Issued to KHL top managers and to heads of KHL departments.

VIP KHL Certificate issued to a KHL employee grants access to all areas of the Sports Facility, except for the Officials’ room, room of Ice Arena Video Goal Judge, team dressing room areas, Doping Control Station, and government boxes during any Championship Game.

Note. Owners of VIP KHL Certificates — KHL Chief Referee and members of Officiating Department — are also entitled to enter the Officials’ room and the room of Ice Arena Video Goal Judge.

KHL TECHNICAL REGULATIONS

Standard KHL Certificate (for KHL representatives)



Issued to KHL employees, KHL Officials and KHL Inspectors.

Standard KHL Certificate issued to KHL employees grants the right to access the Sports Facility and its areas in accordance with functional duties.

The **Standard KHL Certificate issued to Inspectors, Chief Referees and Linesmen, Ice Arena Video Goal Judges** grants the right to access the Sports Facility and, if serving a Championship Game, to the Officials' room and the room of Ice Arena Video Goal Judge.

2. Certificates of KHL Club representatives (2 types: VIP and Standard)

VIP KHL Certificate (for Club representatives)



Issued to KHL Club managers.

VIP KHL Certificate for Club representatives:

- **during a Championship Game in which the Club team takes part:**
grants access to all areas of the Sports Facility, including the team dressing room areas, dressing room of their own Club, except for the Officials' room, room of Ice Arena Video Goal Judge, dressing room of the rival team, Doping Control Station, and government boxes;
- **during a Championship Game in which the Club team does not takes part:**
grants access to the Sports Facility.

Standard KHL Certificate (for Club representatives)

KHL TECHNICAL REGULATIONS



Issued to KHL Club employees.

Standard KHL Certificate issued to Club representatives:

- **during a Championship Game in which the Club team takes part:**
grants access the Sports Facility, team dressing room areas, dressing room of their own Club;
- **during a Championship Game in which the Club team does not take part:**
grants the right to access the Sports Facility.

VIP KHL Certificate cover (for KHL representatives)



KHL TECHNICAL REGULATIONS

Standard KHL Certificate cover (for KHL representatives)



VIP KHL Certificate cover (for Club representatives)



Standard KHL Certificate cover (for Club representatives)



(last updated on 30.08.2018. Minutes of meeting of CHL LLC Board of Directors No. 87 dated 30.08.2018)

VIDEO-GOAL SYSTEM CAMERA LOCATIONS AND IMAGES

Image of the camera inside the goal net



Image of the camera above the goal net

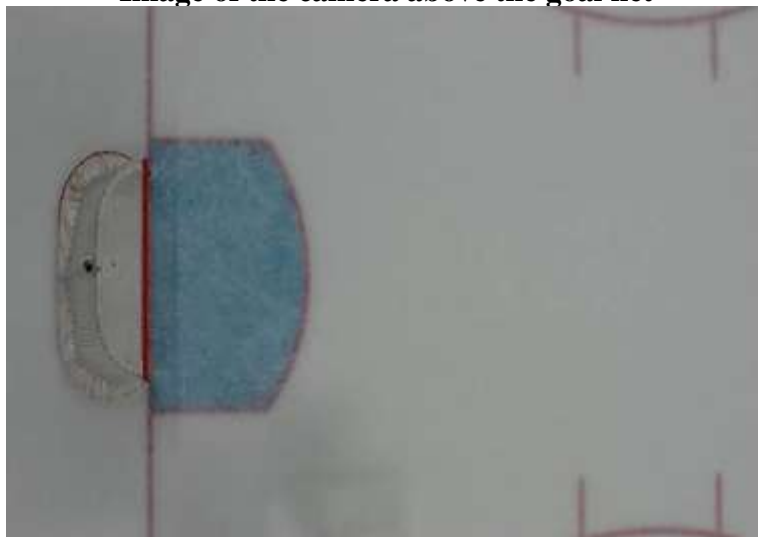
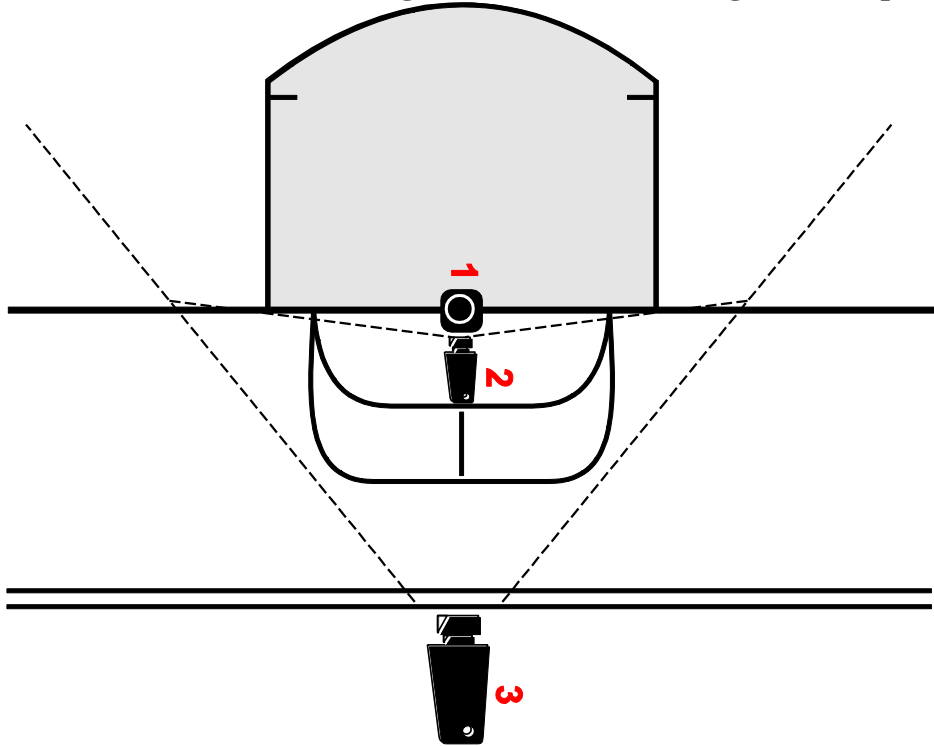

Image of the camera behind the goal net



KHL TECHNICAL REGULATIONS

Locations of cameras above the goal net and behind the goal net (top view)



Locations of cameras above the goal net and behind the goal net (side view)

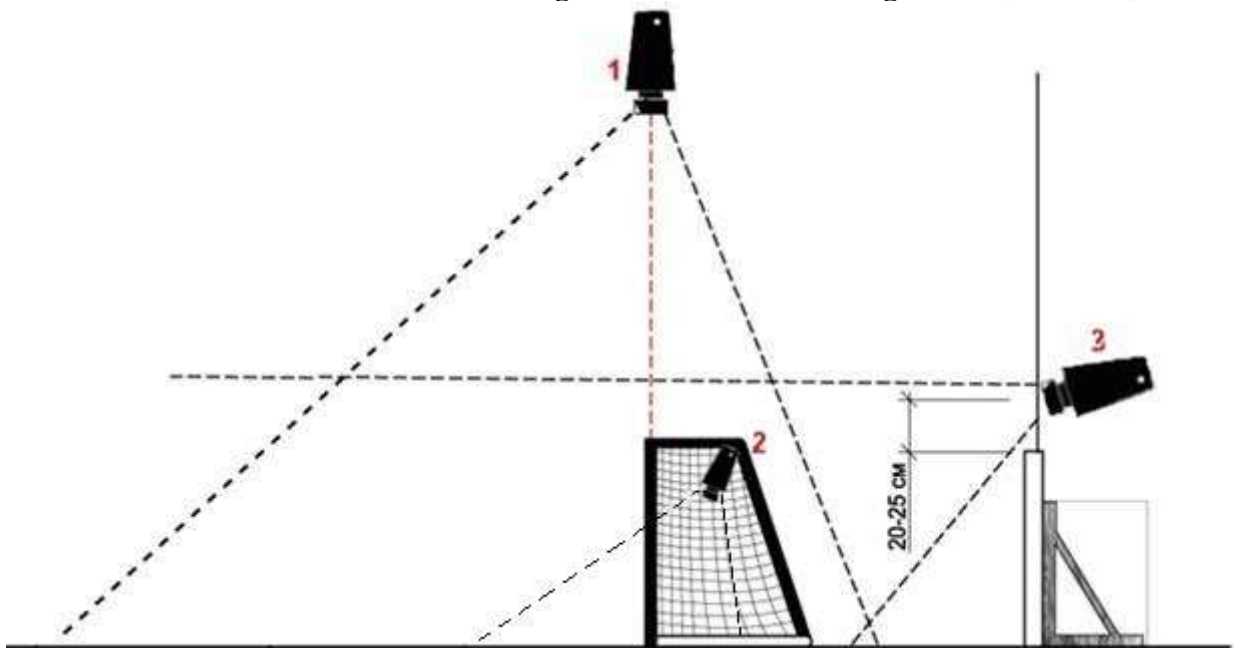

**CODE OF CONDUCT FOR SPECTATORS IN SPORTS FACILITIES
(for KHL and JHL hockey Games)**

This Code of Conduct determines the standards of conduct of spectators in the Sports Facility when attending ice hockey Games held in the Russian Federation and in foreign countries where a “home” Game of a foreign Club is played.

1. General provisions:

- 1.1. The spectators are the persons who enter the Sports Facility, have an entrance ticket, season pass, invitation or other documents of a standard form and are not involved in organization of the Game and any arrangements for holding the Game;
- 1.2. In order to ensure the safety of certain categories of spectators the organizer of the Game may introduce special Game attendance conditions for such categories subject to mandatory notification of the decision to the Sports Facility administration, law enforcement agencies and spectators prior to commencement of ticket sales;
- 1.3. By entering the Sports Facility the spectators accept and voluntarily fulfill requirements of the Code of Conduct in force during their entire visit to the Sports Facility;
- 1.4. Compliance with the Code of Conduct shall be monitored by the organizers of the Game, co-organizers of the Game, law enforcement officers and fire safety inspectors as well as Sports Facility personnel engaged in entrance control, seating spectators and public order maintenance (Sports Facility security personnel, private security companies, stewards, administrators, volunteers, etc.);
- 1.5. The spectators that do not comply with the Code of Conduct as well as the persons subject to the court order that took legal effect in accordance with the legislation and prohibits such persons from visiting competition venues on the days of holding competitions shall be refused entry to the Sports Facility or shall be removed from the venue without ticket price refund and if they commit unlawful acts they shall be held administratively or criminally liable;
- 1.6. Organizers and co-organizers of the Game shall have the right to take photos or videos of spectators for the purpose of unlawful activities prevention;
- 1.7. A breach of the Code of Conduct by a spectator shall serve as the grounds for the organizers of the Game, co-organizers of the Game and Sports Facility administration to consider refusing the breacher the entry to the Sports Facility at the time of holding other Games.

2. Spectators have the right to:

- 2.1. Enter the Sports Facility before and during the Game if they have the tickets, season passes, invitations or other documents of a standard form. The time when admittance to the Sports Facility starts shall be determined by the joint decision of the organizer of the Game, Sports Facility administration and law enforcement agencies. The number of times a spectator may enter the Sports Facility during one Game having the ticket, season pass or other documents shall be determined by the Sports Facility administration;
- 2.2. Enjoy all the services provided by organizers of the Game, co-organizers of the Game and administration of the Sports Facility;
- 2.3. Bring to their seats in the Sports Facility and use:
 - tobacco products and lighters provided that they are used in the zones specially designated for smoking only;
 - memorabilia officially sold by Clubs in Sports Facilities;
- 2.4. Representatives of fan associations shall be allowed, for the purpose of supporting the team in the “fan” and “away” sectors and subject to designating the fans responsible for each item of means of supporting specified below, to bring and use:
 - drums with one membrane and open bottom, diameter of up to 60 cm and height of up to 40 cm, with standard drumsticks;
 - banners of various configurations provided that they are placed at the grandstands in the way that does not create inconveniences for other spectators watching the Game. Banners’

KHL TECHNICAL REGULATIONS

position in the Sports Facility shall be determined by a representative of the Club organizing the Game who is responsible for the safety in consultation with the Sports Facility administration, senior law enforcement officer of the security control center at the Game and EMERCOM representative. The banners shall be made of non-flammable materials (treated with special compounds) and have the appropriate fire safety certificates. The content of the banners shall be aimed only at supporting the Club and shall not contain offensive, obscene, provocative, defamatory texts, words, symbols, images;

(last updated on July 4, 2018. Minutes of meeting of CHL LLC Board of Directors No. 85 dated July 4, 2018)

- flags attached to a hollow plastic staff. The length of the staff cannot exceed 1.5 m. The flags shall be made of non-flammable materials (treated with special compounds) and have the appropriate fire safety certificates. The use of such flags is allowed in the “fan” and “away” sectors. The content of images on the flags shall be aimed only at supporting the Club and shall not contain offensive, obscene, provocative, defamatory texts, words, symbols, images;

(last updated on July 4, 2018. Minutes of meeting of CHL LLC Board of Directors No. 85 dated July 4, 2018)

- other means of team supporting. The use of other means of supporting may be allowed by the joint decision of the organizers, Sports Facility administration and the senior law enforcement officer of the security control center.

The means of supporting containing words and expressions in the official languages of republics of the Russian Federation or official languages of the countries whose Clubs participate in the Championship shall have a translation certified by the Club.

The means of supporting containing words and phrases in a foreign language must have a notarized translation.

The means of supporting containing abbreviations and combinations of digits shall have a written explanation of the meaning of such abbreviations and combinations of digits certified by the Club.

The owners of the above-mentioned means of supporting shall show them 1.5 hours before the Game to representatives of the organizer of the Game, co-organizer of the Game, Sports Facility administration, security control center and EMERCOM who check them for compliance with the requirements.

In the case of violation by the fans of the Code of Conduct, it may be decided to ban the use of the above-mentioned accessories at Games.

- 2.5. Take photos or videos without accreditation using cameras with the lens length not exceeding 20 cm and without any additional equipment, such as tripods, etc. (if their use is not banned by the organizer of the Game, it should be written on the ticket, season pass or invitation).

(last updated on July 4, 2018. Minutes of meeting of CHL LLC Board of Directors No. 85 dated July 4, 2018)

3. The spectators must

- 3.1. Show to entrance control personnel the tickets, season passes, invitations and other documents giving the right to enter the Sports Facility as well as the permits for cars to drive to the surrounding area.
- 3.2. Undergo screening (body search) and display personal belongings for inspection when entering the Sports Facility and in some cases when entering the surrounding fenced area in order to ensure security and prevent smuggling in prohibited items.
- 3.3. Take their seats in accordance with the tickets, season passes and invitations.
- 3.4. Fulfill lawful instructions of the organizer of the Game, co-organizer of the Game, Sports Facility administration, law enforcement officers and fire safety inspectors, observe public order and generally accepted standards of conduct.
- 3.5. Immediately inform the Sports Facility administration and law enforcement officers about any suspicious items, smoke or fire, law infringements being committed, other security threats.

KHL TECHNICAL REGULATIONS

- 3.6. Treat property of the Sports Facility with care, respect cleanliness.
- 3.7. In the case of injury of a person or damage to property of a person as well as damage to property of a legal entity, including the organizer and co-organizer of the “home” Game, indemnify for such injury or damage in full in accordance with the procedure specified by the legislation not excepting satisfaction by him/her (the spectator) of the counterclaim (recourse) of the person that initially indemnified for the injury/damage.
- 3.8. Observe the generally accepted standards of conduct and show respect to the national symbols when before the Game of the Championship there is played the State Anthem of the Russian Federation, anthems of republics of the Russian Federation, anthems of foreign states.

4. The spectators are prohibited from

- 4.1. Being in the Sports Facility under the influence of alcohol, drugs or other intoxicants.
- 4.2. **Bringing** to the Sports Facility and **using**:
 - alcoholic drinks;
 - any kind of weapons and ammunition;
 - piercing and cutting objects;
 - smoke bombs;
 - flares;
 - signal rockets;
 - firecrackers;
 - pyrotechnic products;
 - other substances, items, products including homemade, the use of which may lead to smoke generation, fire and other adverse effects;
 - devices and products, including homemade, not being pyrotechnic products, used for scattering or dispersing different materials and substances (compressed air poppers, etc.);
 - flammable, explosive, toxic and poisonous substances as well as pungent smelling substances;
 - flammable, fire hazardous materials and objects;
 - colorants;
 - narcotic drugs;
 - radioactive materials;
 - nerve and tear gas canisters;
 - laser devices;
 - other objects that can be used as weapons;
 - cans, glass and plastic food containers, bottles;
 - bulky items (any objects whose dimensions in length, width and height exceed $40 \times 40 \times 20$ cm);
 - items the dimensions of which in length, width and height do not exceed $40 \times 40 \times 20$ cm but, in the Game co-organizer’s opinion, may create a hazard to safety of the Game participants or spectators or may become a bar to a normal holding of the Game;
(last updated on July 4, 2019. Minutes of meeting of CHL LLC Board of Directors No. 96 dated July 4, 2019)
 - sound amplification equipment;
 - pipes, whistles of any size, made of any material;
 - rattles made of any material;
 - radio sets;
 - promotional materials of an extremist nature or containing Nazi and/or extremist paraphernalia or symbols;
- 4.3. Smoking using electronic cigarettes and other devices simulating the process of tobacco smoking in the places where it is forbidden by the Sports Facility administration.
- 4.4. Starting fire.
- 4.5. Throwing objects (substances) onto the grandstands, ice and area around it and intentionally throwing objects at spectators, Players, Coaches, Officials, representatives of Clubs, Sports

KHL TECHNICAL REGULATIONS

Facility, law enforcement officers, competition organizer's officials, or using objects (substances) the use of which may, intentionally or unintentionally, result in the landing of such objects (substances) or parts thereof in the above places or onto the above persons. The exception is throwing caps onto the ice by fans if during one Game of the Championship a player of the playing teams scores 3 (hat-trick) or more goals. Throwing caps onto the ice under these circumstances is adherence to the world hockey tradition and is not dangerous for participants of the Game.

(last updated on July 4, 2019. Minutes of meeting of CHL LLC Board of Directors No. 96 dated July 4, 2019)

- 4.6. Wearing and flaunting as well as using emblems, symbolics and other Nazi and extremist paraphernalia as well as using emblems and symbolics confusingly similar to them; publicly displaying any extremist paraphernalia.
- 4.7. Using words and expressions as well as gestures of fascist and racist nature.
- 4.8. Using obscene, offensive, defamatory words and expressions as well as gestures.
(last updated on July 4, 2018. Minutes of meeting of CHL LLC Board of Directors No. 85 dated July 4, 2018)
- 4.9. Using symbolics, banners, chants, shouts or gestures that incite social, racial, religious, national and interstate hatred as well as social, racial, religious, national and interstate superiority.
- 4.10. Insulting other persons in particular using means of supporting and paraphernalia and committing other actions discrediting the honor, dignity and business reputation of a person or a group of persons or a legal entity.
- 4.11. Using items of clothes and other objects and methods to hide the face.
- 4.12. Violating public morals and norms of behavior by baring body parts while in the Sports Facility.
- 4.13. Behaving in a provocative or threatening way in respect of spectators and participants of the Game, creating threats to their life and safety or life and safety of other people or endangering anyone in any way whatsoever.
- 4.14. Going beyond the fences to the ice rink and onto the ice rink, to dressing rooms of the teams and Officials, to Press Centers and other auxiliary premises.
 - 4.14.1. Entering the areas adjacent to the Sports Facility access to which is restricted by the organizer of the Game or the owner of the Sports Facility, as well as entering the Sports Facility zones not indicated in the ticket or in the document that substitutes it access to which is restricted by the organizer of the Game or the owner of the Sports Facility (ice rink and technical zones around the boards, media zone, zone for distinguished guests, technical premises, etc.).
(last updated on July 4, 2018. Minutes of meeting of CHL LLC Board of Directors No. 85 dated July 4, 2018)
- 4.15. Being in the aisles or on the stairs during the Game, interfering with the movement of participants and spectators, standing on chairs, jumping, simulating illegal actions, climbing on fences, parapets, lighting equipment, masts, supporting structures, damaging the property of the Sports Facility and spectators.
- 4.16. Bringing animals to the Sports Facility.
- 4.17. Committing any political acts and promotion actions.
(last updated on July 4, 2019. Minutes of meeting of CHL LLC Board of Directors No. 96 dated July 4, 2019)
- 4.18. Taking any public actions not approved by the organizer of the Game.
- 4.19. Selling or otherwise distributing advertising materials, souvenirs, materials of political, religious and racist nature (including posters, leaflets, brochures).
- 4.20. Illegally selling tickets to the Game.

DESIGNED SPORTS FACILITIES

1. In addition to the above-mentioned requirements of the KHL Technical Regulations, the design of a new Sports Facility for holding the Championship Games must provide for the following:
 - 1.1. Number of individual seats — no less than 12,000 in cities with a population of more than 500,000 people. In cities with a population of up to 500,000 people, no less than 9,000 individual spectator seats. In cities where two or more Clubs participating in the KHL Championship are based, no less than 9,000 individual spectator seats.
 - 1.2. 60 × 30 m hockey rink with a technical option to transform its size (60 × 28 m and 60 × 26 m).
 - 1.3. Board system compliant with the requirements specified in Appendix 9 to the KHL Technical Regulations.
 - 1.4. At least four dressing rooms with an area of 100 m² each without taking account of premises adjacent to the dressing rooms (at least six shower cabins, no less than three toilet cabins, massage rooms, etc.).
 - 1.5. Premises equipped with washing machines for sports uniform washing.
 - 1.6. Separate entrances to the Sports Facility for the host team and the visiting team located near their dressing rooms and at a considerable distance from the entrance and the room for the Chief Referees and Linesmen.
 - 1.7. Separate entrance to the Sports Facility for the Chief Referees and Linesmen located close to the room of Chief Referees and Linesmen and at a considerable distance from teams' entrances and dressing rooms.
 - 1.8. Separate areas for dressing rooms and premises of the host team and visiting team adjacent to the dressing rooms.
 - 1.9. Separate area for the Chief Referees and Linesmen room.
 - 1.10. Two gym halls for quick warm-up of the host team and the visiting team.
 - 1.11. Separate premises for the quick warm-up of the Chief Referees and Linesmen located close to the room of the Chief Referees and Linesmen.
 - 1.12. Separate entrances to the ice rink for the host team, visiting team, as well as for the Chief Referees and Linesmen.
 - 1.13. Equipped seats at the grandstands for Mass Media representatives located close to the Press Center, room for press conferences, and staff entrance through which the Mass Media representatives enter the Sports Facility.
 - 1.14. An area at one of the central sectors (within the neutral zone of the ice rink) at the Sports Facility grandstands for at least ten (10) accredited photographers.
 - 1.15. Equipped seats at the grandstand for medical personnel on duty that shall be located close to the maintenance gate for ice-resurfacing machines.
 - 1.16. Room for the Officials' team and the Official Game Report Execution located close to the Officials' desk.
 - 1.17. Two interconnecting rooms for the Medical Station compliant with sanitary regulations and standards 2.1.3.2630-10: doctor (paramedic) room — 15 m², sanitary room — 8 m², cloakroom entrance for visitors — 4 m², toilet facilities — 3 m².
 - 1.18. Three interconnecting rooms for doping control compliant with sanitary regulations and standards 2.1.3.2630-10: waiting room — 18 m², room for medical procedures — 12 m², toilet facilities — 3 m² (toilet and washbasin). The premises shall be located in the dressing room area or close to it.
 - 1.19. Premises for the Club doctor compliant with sanitary regulations and standards 2.1.3.2630-10 and including at least the following: doctor's office — 12 m², room for medical procedures — 12 m², massage room — at least 10 m², toilet facilities — 6 m² (toilet, washbasin); and the room of the visiting team doctor (no less than 8 m²) interconnected with or close to the visiting team dressing room.
 - 1.20. Designated seats at the grandstands (at least five (5)) for disabled people and at least five (5) seats for accompanying persons ensuring barrier-free environment and the respective passages. Such seats must be equipped with special appliances (ramps, elevators) for free movement and

KHL TECHNICAL REGULATIONS

access of persons with disabilities related to supporting-motor system, using wheelchairs, as well as equipped with a toilet cabin for this category of people. The toilet cabin shall be equipped with a washbasin with a pedal-type mixer, a mirror above the washbasin located at the right height, hinged handrails at the flush toilet area, a paper tissue or towel container, open-type toilet paper holder or dispenser, a liquid soap container, a wastebasket. Height must be convenient for this category of people. External ramps must have handrails taking account of technical requirements for stationary supporting devices. On the territory adjacent to the Sports Facility, there must be a designated parking area for at least five cars transporting disabled people.

- 1.21. Separate entrance to the Sports Facility to ensure the shortest route to the “away” sector for the visiting team supporters.
- 1.22. Men’s and women’s toilets located in the “away” sector area.
- 1.23. Public meals stations located in the “away” sector area.
- 1.24. Access and parking areas for vehicles that are used to deliver the teams, Officials, their equipment close to the respective entrances making it possible to ensure their security.
- 1.25. Areas for convenient access and parking of ambulance vehicles close to the respective entrances.
- 1.26. Cloakrooms in the adjacent territory of the Sports Facility where spectators can leave their items that are prohibited to carry on to the Sports Facility.
- 1.27. Parking areas for spectators’ cars in the territory adjacent to the Sports facility shall be organized. VIP parking area must be organized close to the VIP entrance to the Sports Facility with a convenient access for vehicles. The parking area shall provide sufficient space for the incoming vehicles and have high throughput.

**REQUIREMENTS FOR PREPARING AND USING
THE ICE SURFACE****1. Concrete slab preparation**

- 1.1. Before freezing of water, the concrete slab shall be carefully washed with clean water (from the municipal water system) without using any special household chemicals.
- 1.2. If the concrete slab is painted, two layers of frostproof dazzling-white facade acryl paint shall be used. Once the slab is completely dry, it should be cooled for creating solid ice.

2. Creating the solid ice

- 2.1. The lower ice layer must ensure adherence with the concrete wall to avoid exfoliation.
- 2.2. When creating the first ice layer, hose flooding is used with an average layer thickness of 1 mm each.
- 2.3. The average thickness of the first ice layer shall be 10–12 mm.

3. Painting the ice rink

- 3.1. If the ice rink is painted in white color, special-purpose professional paints similar in quality to Superweiss 3000, Ice Pack or Jet Ice White 3000 shall be used. After painting, protective ice layer shall be created of 10 to 12 mm thickness regarding the requirements of the paint manufacturers.

(last updated on July 4, 2019. Minutes of meeting of CHL LLC Board of Directors No. 96 dated July 4, 2019)

- 3.2. The ice surface must be smoothed, any traces of paint surfacing shall be taken care of.
- 3.3. Then, ice must be trimmed, and the smoothing layer shall be created.

4. Marking and advertisement

- 4.1. Marking is created on smooth ice using paint of the respective color.
- 4.2. Advertisement banners are laid and iced. Then, the banners are cut along the key drawing making sure the banner edges do not surface. Once the paint and banners have frozen, protective ice layer of at least 1.5 mm shall be created.
- 4.3. The shade of the white color of banners under the ice must be the same as the shade of paint on the ice surface using the selected color system (NCS, RAL, etc.).
- 4.4. To reduce chemical effect of the banner's material on ice, it should be thoroughly washed by water from the flooding hose without extra pressure before laying. It is expressly prohibited to scrub the banner using brushes (or other tools).
- 4.5. When selecting the in-ice banner material, a Club is recommended to test its humidity permeability, moisture-retaining power and chemical reactivity to avoid its surfacing and other negative impacts on the ice quality.
- 4.6. To increase the ice thickness to the level at which ice-resurfacing machines can move without damaging banners, hose flooding is used.
- 4.7. The remaining ice of the specialized surface shall be performed by ice-resurfacing machines.

5. Outer ice layer

- 5.1. "Water towel" shall be used during flooding by ice-resurfacing machines.
- 5.2. The outer ice layer thickness shall be 10–20 mm, while the total thickness of ice shall be no less than 35 mm and no more than 50 mm.
- 5.3. The outer ice layer shall be renewed at least three times for a season.

KHL TECHNICAL REGULATIONS

6. Ice surface layers scheme

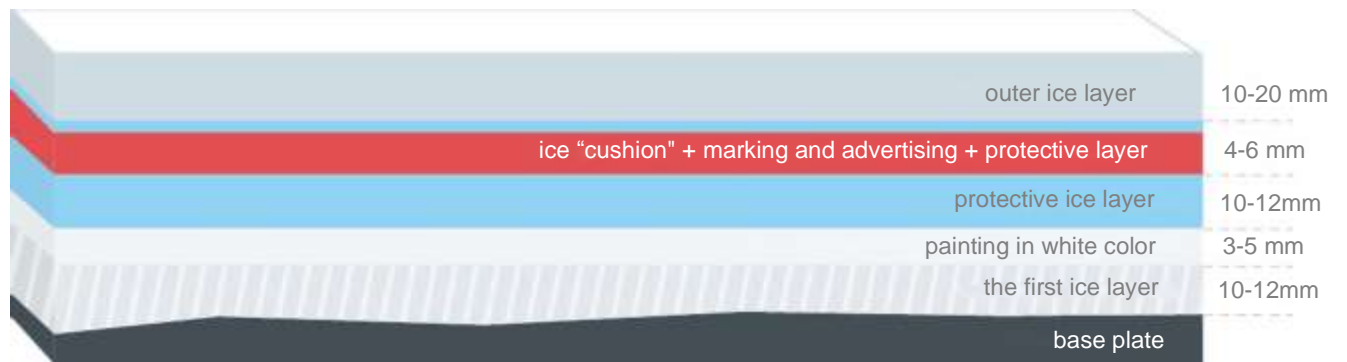

BOARD SYSTEM REQUIREMENTS

1. Lifetime of board systems

- 1.1. A board system lifetime shall be no more than 12 years from the initial installation of the board system.
Board systems that have been used for 12 years must be replaced by board systems compliant with this Appendix to the KHL Technical Regulations.
(last updated on July 4, 2019. Minutes of meeting of CHL LLC Board of Directors No. 96 dated July 4, 2019)
- 1.2. The replacement of acryl safety shield is performed depending on its condition during the lifetime of board systems. The condition is determined by KHL inspections of Sports Facilities.
- 1.3. The acryl safety shield installed on top of the board shall be replaced depending on its condition during the lifetime. The condition is determined by KHL inspections of Sports Facilities.

2. Ice hockey rink size

- 2.1. Maximum size is **60 m** lengthwise and **30 m** broadwise.
- 2.2. Minimum size is **56 m** lengthwise and **26 m** broadwise.
- 2.3. The rink corners must be rounded by a radial arc with the radius of **7–8.5 m**.

3. Board

- 3.1. Board height shall be **107 cm** above the ice surface (from the ice surface to the upper horizontal plane of the shelf).
- 3.2. The board surface on the ice side must be smooth, have no cusps, roughness or obstacles that may result in Players' injuries or modify the natural puck movement.
- 3.3. In the upper part of the board alongside the entire perimeter, a shelf shall be installed to designate the border between the board and the safety shield.
- 3.4. Full size of the shelf (distance from the vertical plane of the safety shield and the shelf edge on the board surface on the ice side) shall be no more than **40 mm**. The shelf shall be rounded with a radius of at least **20 mm**. The slip (friction) factor of the shelf must be uniform with respect to the board surface and barrier elements.
- 3.5. At the board basement, a yellow kick plate shall be installed with a height of **15–25 cm** above the ice surface.
- 3.6. All doors for entering the ice rink shall be opened to the outer side of the rink.
- 3.7. The gap between the doors and the board shall be minimized to **5 mm**.
- 3.8. The board shall amortize the hit during the power physical contact.
- 3.9. The gap between the board panels shall be minimized to **3 mm**.

KHL TECHNICAL REGULATIONS

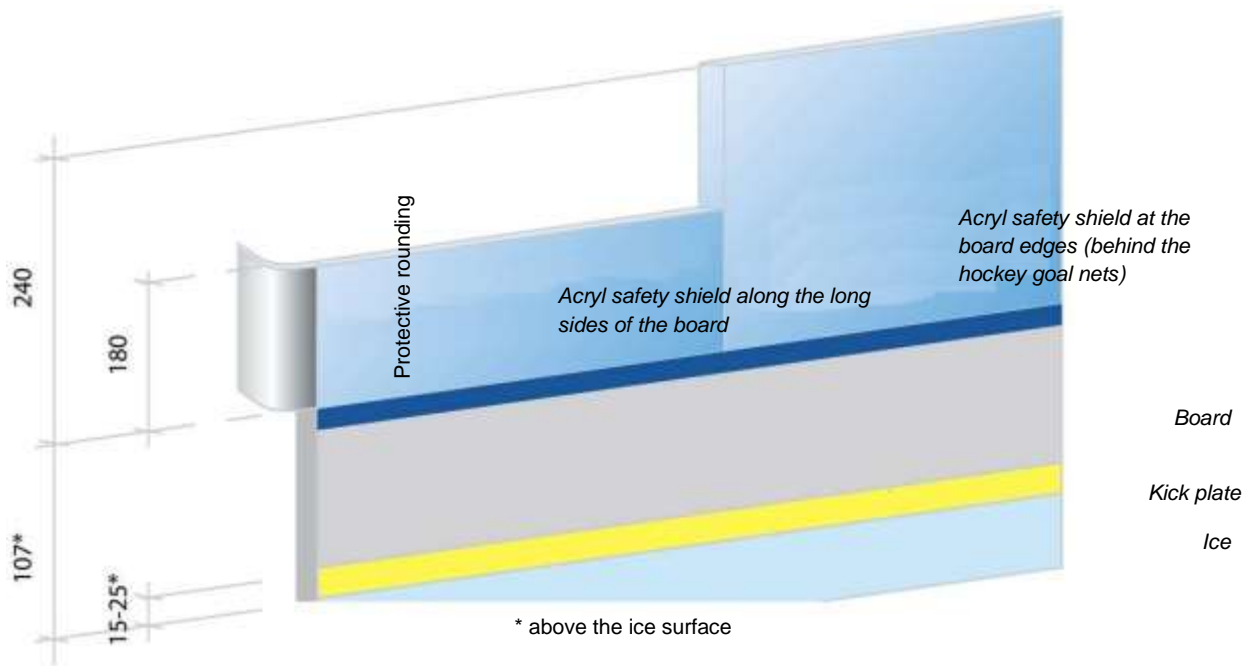

4. Safety shield

- 4.1. Alongside the entire perimeter of the board during the KHL Championship, a **transparent acryl safety shield** shall be installed. The shield width shall be **15 mm** and height — **180 cm** at the longer sides of the board, except for the area in front of the Players' Bench; the height shall be **240 cm at the board edges behind the hockey goal nets** and continued along the board radius and longer sides towards the neutral zone for **4 m** off the goal line.
- 4.2. In the areas where the shield is not installed in front of the Players' Benches, a **shock-absorbing rounding of polycarbonate or acryl with the radius of 500 mm** shall be installed for protecting Players against injuries.

The acrylic safety shield and the shock-absorbing rounding of polycarbonate or acryl shall be connected throughout the height with a red strip, 80 mm wide and 1800 mm high, which is a divider of the limits of the hockey rink and the Players' bench (*Fig. 1*).

(last updated on July 4, 2019. Minutes of meeting of CHL LLC Board of Directors No. 96 dated July 4, 2019)



Figure 1

- 4.3. Gaps between safety glass shall be closed by special sections or inserts.

KHL TECHNICAL REGULATIONS

- 4.4. Safety shield sections are installed so that any section can be replaced without damaging the integrity of other sections.
- 4.5. The 15 mm wide acryl safety shields installed on the board shall amortize the hit during the power physical contact between Players.
- 4.6. The safety shield must prevent contacts between Hockey Players, team representatives, game Officials and spectators, as well as appearance of items thrown from the stands to Players' Benches, Penalty Boxes and game Officials.
- 4.7. It is prohibited to drill any holes in the safety shield that may result in injuring a Player or modify the natural puck movement, excluding the hole (**diameter — 10 cm**) in front of the Game Secretary for communicating with the Chief Referee of the Game.
- 4.8. Metal supporting poles are allowed in the spectator shield system only in the area of maintenance gates and doors (Penalty Box, access door).

KHL TECHNICAL REGULATIONS

Table 1 of Appendix 9

Deleted.

(last updated on July 4, 2019. Minutes of meeting of CHL LLC Board of Directors No. 96 dated July 4, 2019)